

**SELLS  
ON  
SIGHT**



MILTON S. FERGUSON  
HUGHES A-C  
1500 EL PASO LANE  
FULLERTON CA 92633  
71

**superior readability that competitors can't match**

One look at an operating SELF-SCAN<sup>®</sup> panel display and you will know why you should be featuring one in your system. SELF-SCAN displays are a new solution to the operator machine interface that provides advantages to the system builder, to the system user, and to the system operator.

You can offer your customer the advantage of a custom-stylized unit that his operators can use efficiently. SELF-SCAN panels are measurably superior to CRT for operator accuracy while significantly reducing fatigue level in day in-day out high volume production applications.

The 0.2" high characters are in the popular 5x7 dot matrix format and are made up of dots on .040" centers. The unit is ASCII compatible and displays a modified 64-character ASCII character set.

256-character display subsystems are available from stock for immediate delivery. Call or write Burroughs Corporation, Electronic Components Division, Box 1226, Plainfield, New Jersey 07061, Phone: (201) 757-3400. Ask to have a Burroughs sales engineer stop by your office and show you his 256-character SELF-SCAN panel, keyboard, and power supplies packaged in a standard Samsonite<sup>®</sup> briefcase.



Circle Reader Service Card No. 35

Volume 9 Number 4 July/August 1972

# Information Display

*The Journal of Data Display Technology*

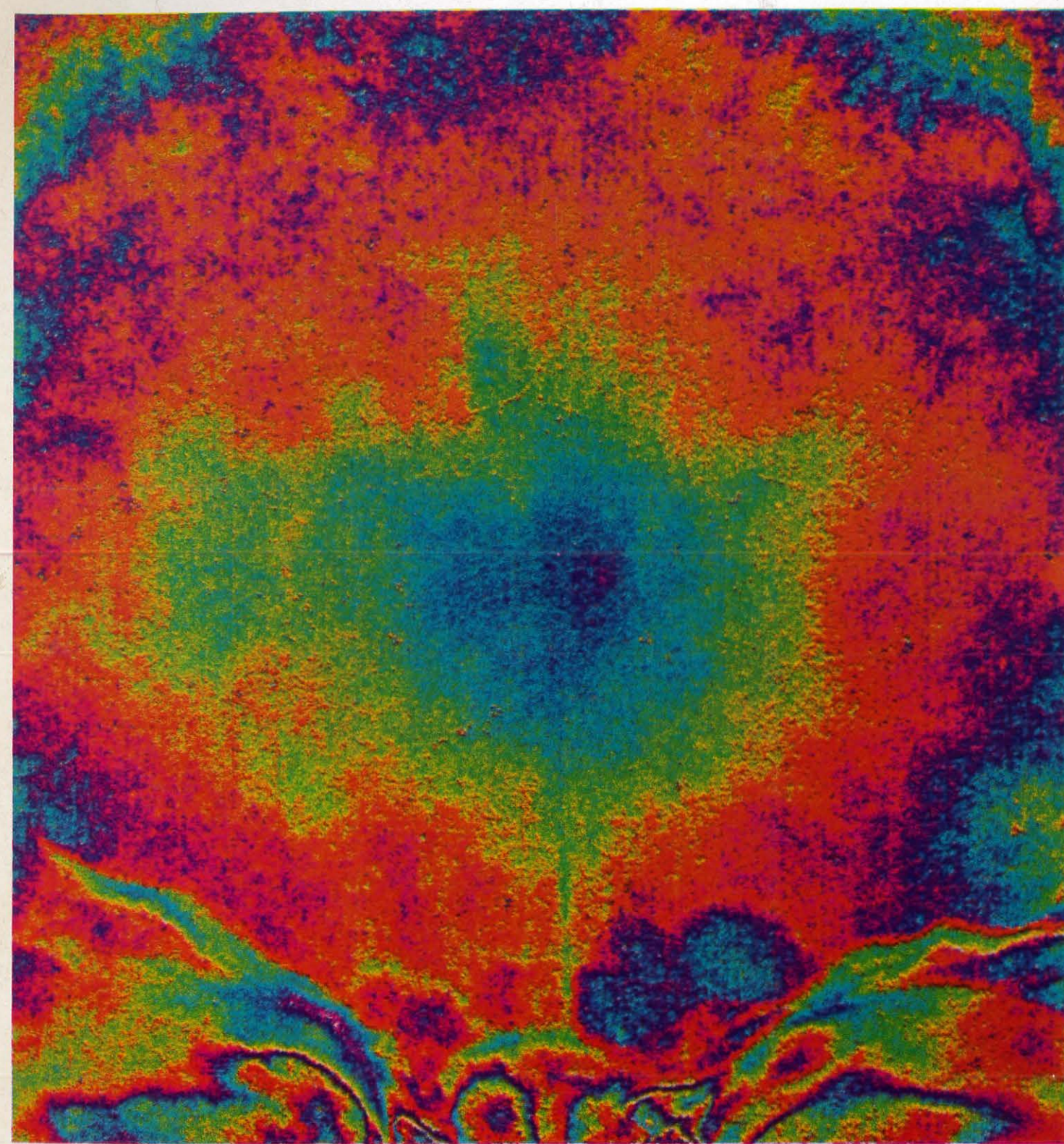

A Technology Publishing Corp. Publication



# for Digital Image Processing you need ...

## ...INPUT

### the DICOMED 57 IMAGE DIGITIZER

A versatile general purpose film scanner providing:

- Scanning resolutions to 2048 points per axis
- grey scale resolution to 256 steps
- random point or raster scanning
- area scanned is selectable
- variable scanning speeds
- program-controlled operation
- pre-processing by signal range expansion



## ...OUTPUT

### the DICOMED 36 IMAGE DISPLAY

A high resolution storage display incorporating:

- resolution to 2048 points per axis
- 64 possible intensity levels
- no refreshing
- raster scanning or random point plotting
- simultaneous display of multiple images
- automatic formatting
- high stability permits image overlays

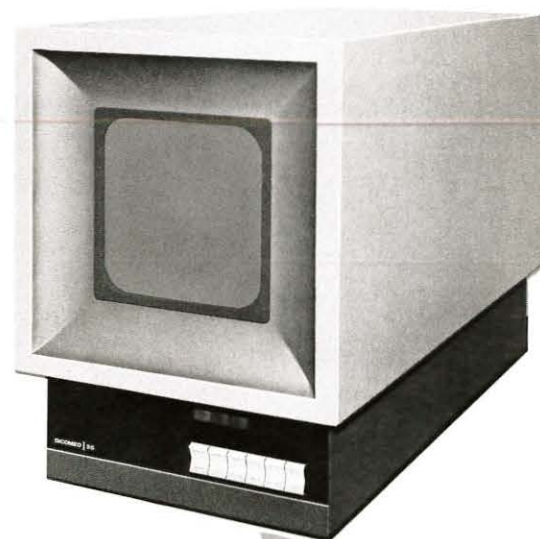

**FOR MORE INFORMATION CONTACT  
THE IMAGE ANALYSIS PEOPLE AT ...**



the DICOMED Corporation

7600 PARKLAWN AVENUE  
MINNEAPOLIS, MINN. 55435  
(612) 920-8980

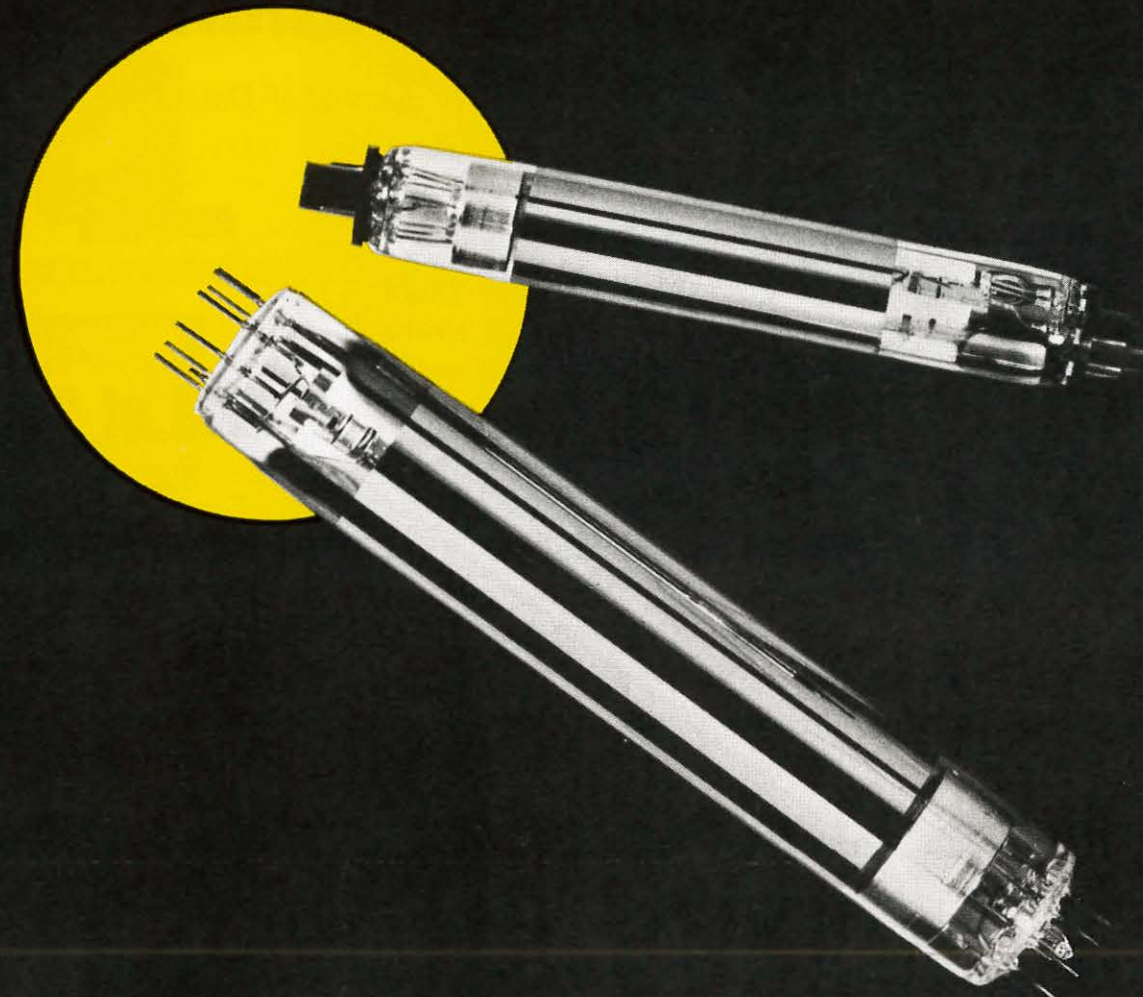

## Meet RCA's new family of silicon target storage tubes—sister products of the SIT camera tube used on the moon

Here's the new storage tube line — with performance levels enhanced by a silicon target — you've been waiting for. Designed for a wide variety of TV display applications, these devices are extensions of the silicon technology used in the Apollo 15 camera tube.

RCA-C22041 is typical of this family of single-ended, non-destructive readout storage tubes with silicon target. Use it and the companion tubes in such diverse applications as frame freeze, low-light-level TV signal enhancement, information storage and retrieval, picture transmission over

phone lines, specialized graphic display terminals, and buffer memories for document retrieval systems.

Designed to operate over a wide range of input and output rates in a variety of operating modes, the RCA family of silicon target storage tubes includes:

Type	Dia. Inches	Resolution Lines	Deflection Method	Reading Duration Mins.
C22041	1	1200	M	5
C22045	1½	1700	M	10
C22047	1	1200	M	10

For consistent high quality and reliability in your display systems, look into RCA's new silicon target storage

tube line. For more information, see your RCA Representative. For technical data on type C22041, write: RCA, Commercial Engineering, Section 86G /ZD1, Harrison, N.J. 07029. International: RCA, 2-4 rue du Lièvre, 1227 Geneva, Switzerland, or Sunbury-on-Thames, U.K., or P. O. Box 112, Hong Kong.

**RCA** Electro Optics



## Information Display

Published bimonthly by  
Information Display Publications, Inc.  
825 S. Barrington Ave. (213) 826-8388  
Los Angeles, Calif. 90049

[Correspondence regarding feature articles, advertising, reprints and nonmembership subscriptions should be directed to the above address.]

EDITORS & PUBLISHERS . . . Martin Waldman  
Hal Spector  
EDITORIAL CHAIRMAN . . . . . R.L. Kuehn  
FEATURE EDITORS . . . . . T. Simkins  
C. Schmidt . . . . . M. Farley  
EDITORIAL COORDINATOR . . . B. Atchison  
PRODUCTION MANAGER . . . . C. Camburn  
CIRCULATION MANAGER . . . . P. Goldberg  
BUSINESS MANAGER . . . . . S. Graham  
ADVERTISING . . . . . Donald Meeker

CLOSING DATES—Editorial closing date is first of month preceding month of issue. Advertising closing is first of month preceding month of issue.

CHANGE OF ADDRESS notices should be sent promptly; provide old mailing label as well as new address; include ZIP code or postal code. Allow two months for change.

SUBSCRIPTIONS for U.S., its territories, possessions and Canada: \$20 per year; \$35 for two years; \$45 for three. Single copy price, \$4.00. Foreign countries: \$40 per year; \$70 for two years; \$90 for three years. Complaints concerning nonreceipt of magazines must be made within four months of issue mailing date.

EDITORIAL CONTRIBUTIONS must be accompanied by stamped return envelopes and will be handled with reasonable care; however, publishers assume no responsibility for safety of artwork, photographs or manuscripts. Every precaution is taken to ensure accuracy, but the publishers cannot accept responsibility for the correctness or accuracy of the information supplied herein or for any opinion expressed.

## Guide to Contributors

1. Copy is to be typed, double spaced, on white paper.
2. Number manuscript pages consecutively.
3. Arrange material in sequence: first cover page containing your name and title of paper, summary page next, followed by manuscript, and ending with reference page in which previously numbered references are identified.
4. Refer to graphs, diagrams, illustrations in text as Figure 1, Figure 2, etc. Identify material on back, and include your name.
5. Send recent "mug shot," wearing business suit with shirt and tie. Please write your name on back of picture.
6. Enclose recent and brief resume, listing educational background, job affiliations and titles, professional accomplishments, and professional/technical membership.

© 1972 BY INFORMATION DISPLAY PUBLICATIONS, INC. ALL RIGHTS RESERVED. REPRODUCTION IN WHOLE OR PART WITHOUT WRITTEN PERMISSION IS PROHIBITED.

CONTROLLED CIRCULATION POSTAGE  
PAID AT LOS ANGELES, CALIFORNIA

Volume 9 Number 4

July/August 1972

# Information Display

The Journal of Data Display Technology

## Table of Contents

### Articles

- A TELEVISION COMPATIBLE CHARACTER GENERATOR 13  
*S.N. Baron*  
Discusses an electronic character generator creating television graphics.
- STANDARD THEATRE STEREOPTICS WITHOUT GLASSES: Part I 18  
*R.B. Collender*  
A new concept of geometry with suggested implementation is presented which allows single point projection from existing theatre projection booths.
- CRT WRITE RATE VS BANDWIDTH STUDY 27  
*A. Pletz Jr.*  
Ties together the relationship between CRT write rate and deflection amplifier bandwidth.

### Features and Departments

- EDITORIAL: The Peripheral Computer 10
- NEW LITERATURE: Data available 32
- CORRESPONDENCE: Readers share their views 33
- ID PRODUCTS: Innovations from many firms 34
- ID READOUT: Industry news 36
- ADVERTISERS 36

### The Cover

Density, abnormality and location data of clinical x-rays are substantially more accessible with computer enhancing, as illustrated in this display of a frontal skull x-ray, courtesy of Data Corporation.

INFORMATION DISPLAY, July/August 1972

# We build better monitors.



Setchell Carlson equipment has been playing a vital role in television display for more than twenty years. We believe the reputation of the Setchell Carlson name speaks for itself. We have a full complement of monochrome and color video displays and RF receivers supplied to a variety of industries, the education market, and for security/surveillance applications.

Many of our monitors are being applied to information retrieval systems. They are admirably suited for this application since SC Electronics' exclusive UNIT-IZED® modular, all solid-state construction means less heat for considerably longer life, less frequent and easier maintenance, and significantly shorter "down time".

Look into Setchell Carlson displays for your applications. If we don't build exactly the screen size or configuration for your specific needs, we have the design capability for almost any custom adaptation. Call or write today.

At SC Electronics we set the pace.

# We can build one just for you.

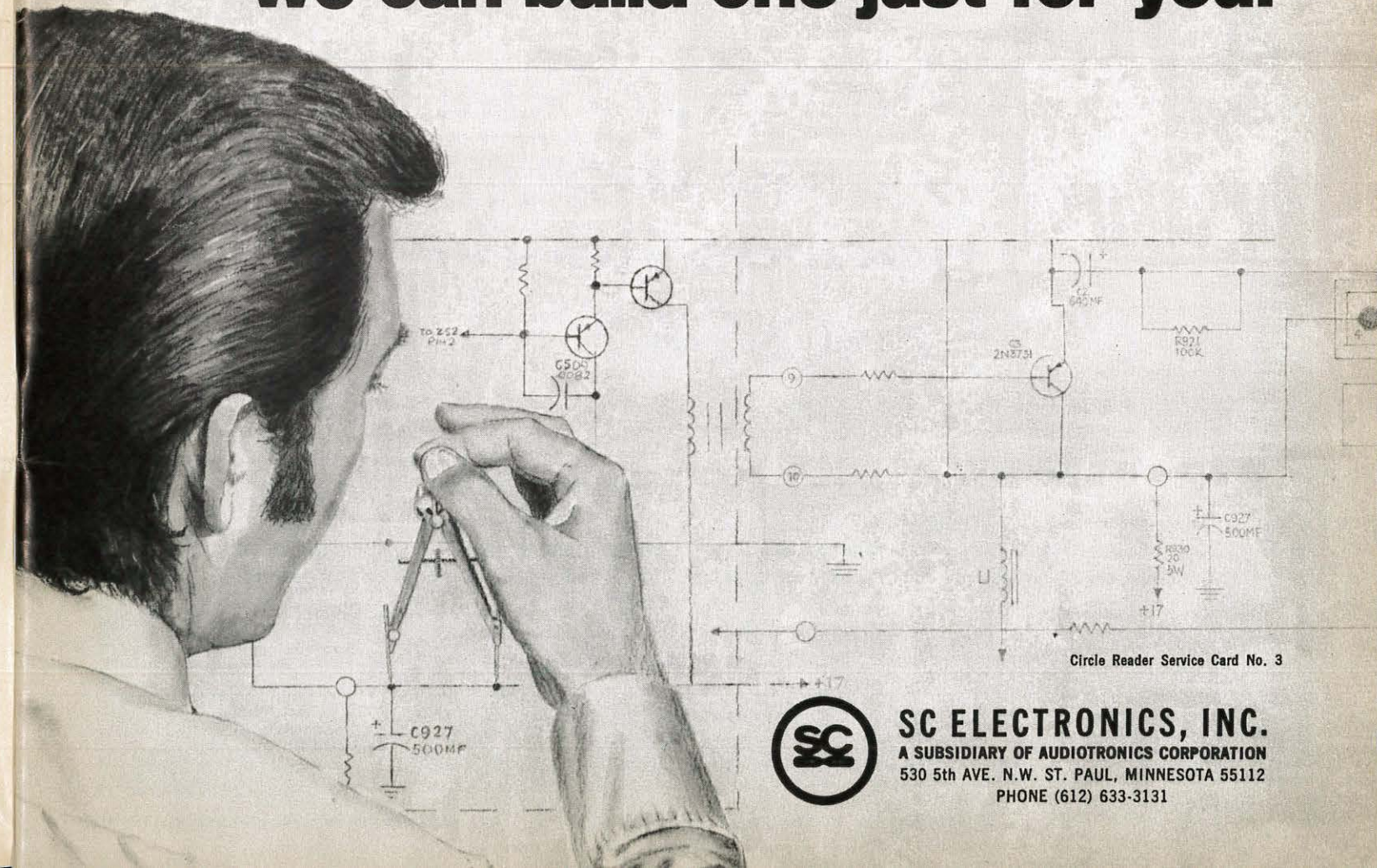

Circle Reader Service Card No. 3



**SC ELECTRONICS, INC.**  
A SUBSIDIARY OF AUDIOTRONICS CORPORATION  
530 5th AVE. N.W. ST. PAUL, MINNESOTA 55112  
PHONE (612) 633-3131



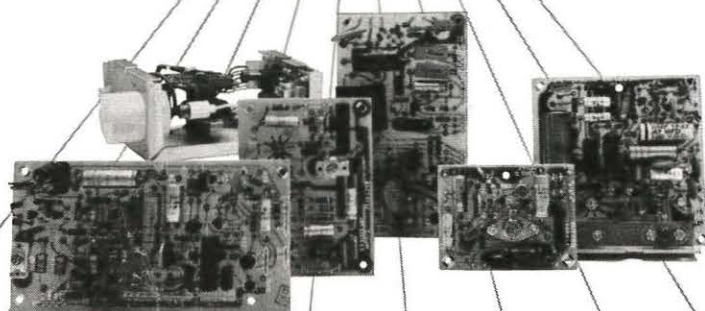
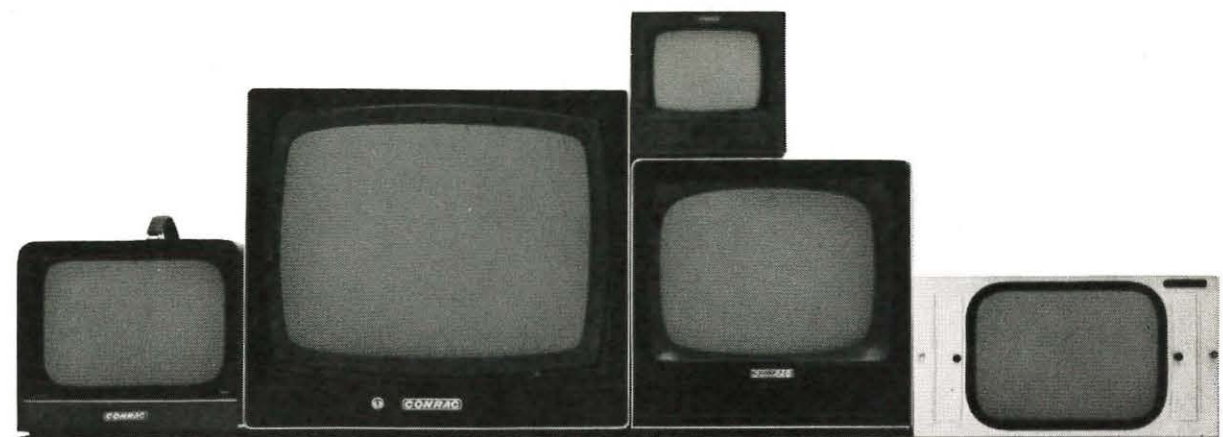

**Which model  
do the  
boards go in?**

Any one of them. Conrac is introducing a new generation of monochrome broadcast-quality monitors. The same high voltage module and five quick-disconnect boards work in every model of the new series. They're interchangeable, and that's a big feature. You get the operational flexibility of being able to "board snatch" when needed. Reduced requirement for component stocking. Ease of maintainability.

You also get the next generation of Conrac monitors designed to meet the stringent requirements of broadcasting. Conrac's new series "S." A complete selection of black and white monitors. All solid state. Designed for UL approval. Your choice of 9-, 12-, 14-, 17- or 23-inch kinescopes. Available as cabinet, chassis, or rack-mount models with several important broadcast options. Write for details.

**CONRAC**  
CORPORATION

600 N. Rimsdale Avenue • Covina, California 91722 • (213) 966-3511

# KNOWLEDGE IS POWER!

now you can  
update your knowledge  
with these  
two valuable books:

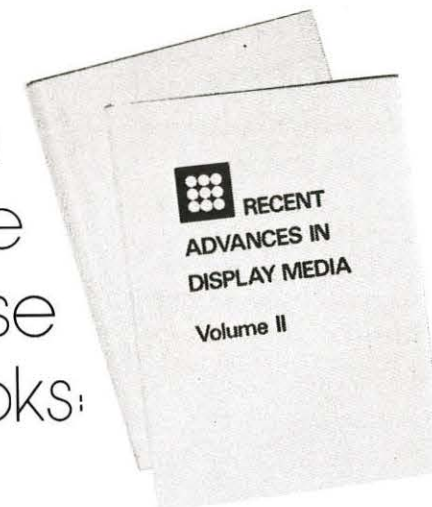

## RECENT ADVANCES IN DISPLAY MEDIA VOLS. II & III

Get them while there's still a supply available...and save money too!

These two fact-filled volumes cover the newest information in display advances. They take up where Volume I left off...and it sold out completely!

Now there are still ample copies of Volumes II & III on hand, and they're filled with a wealth of update reports to help every engineer, systems designer, display manufacturer and display user keep current on new theories and techniques. With so much happening, you've got to stay informed to be truly effective!

Authored by a number of top computer display experts, these all-new volumes represent the most pertinent, authoritative and up-to-date source of information on computer terminals; character line and curve generators; memory discs; digital printers and plotters; CRT's; over-all system considerations; and more.

Contents include...VOL. II (261 pp): *A Plasma Display Terminal* ★ *VTOR IFR Technology Program* ★ *A General Description*

*of the Fallout Display System (FODS)* ★ *R&D in the Computer and Information Sciences* ★ *Computer Processing for Display of 3-Dimensional Structures*.

VOL. III (231 pp.): *The Impact of Electronic Displays on Aircraft Control* ★ *Digital Printer/Plotter Graphics Terminal* ★ *An Experimental Display Processor for the DX-1* ★ *Information Acquisition, Sensing and Input: A Selective Literature Review* ★ *R&D in the Computer and Information Sciences*.

With the information available here, you can keep ahead of the technology avalanche that threatens to bury many of today's engineers. *Recent Advances in Display Media, Vols. II & III*, are available singly, or together at a special limited-time price.

And remember, business and professional books are tax deductible (authority: Treas. Reg. 1.162; I.R.C. 162). So act right now and start making use of these valuable books to advance your company and your career!

### Order Now and Save \$!

**Vols. II & III, ordered together before September 1, only \$34.95!**

Please send VOLS. II & III together \_\_\_\_\_ for only @ \$34.95

Please send \_\_\_\_\_ copies of Recent Advances, VOL. II @ 20.00

Please send \_\_\_\_\_ copies of Recent Advances, VOL. III @ 20.00

Check, Cash or Money Order enclosed (amount) \_\_\_\_\_

Please bill my company in advance (amount) \_\_\_\_\_

My name is \_\_\_\_\_

Company name is \_\_\_\_\_ P.O. No. \_\_\_\_\_

Mailing address \_\_\_\_\_

City \_\_\_\_\_ State \_\_\_\_\_ Zip \_\_\_\_\_

Date \_\_\_\_\_ Signature \_\_\_\_\_

**Complete satisfaction guaranteed! Immediate refund available on 10-day return privilege... we pay postage both ways**

Prices:  
Vols. II & III together ..... \$34.95  
One Copy (either) ..... \$20.00  
Three or more copies ..... @ \$14.95  
Eleven or more copies ..... @ \$10.00

Please send this coupon, with check payable to:

**TECHNOLOGY PUBLISHING CORP. • 825 S. Barrington Ave., Los Angeles, Calif. 90049**  
(Calif. residents add 5% sales tax)



POLACOAT  
**LENSCREEN**<sup>®</sup>  
 REAR PROJECTION SCREENS

**GLASS**

Many users choose glass because of its durability, ease of cleaning, maximum scratch resistance and stability.

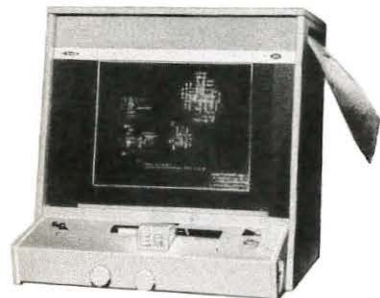

**ACRYLIC**

Preferred in specific instances, acrylic is break-resistant and lightweight.



**LENSCREEN**  
 REAR PROJECTION SCREENS  
 OFFER YOU:

- Selection of Gain Ranges
- Excellent Resolution
- Moisture Resistance
- A variety of thicknesses
- Custom cut sizes
- Neutral gray
- Choice of colors
- Polished or No-Glare finish
- Hy-Dur finish available

Technical Assistance and Data Available upon Request

**POLACOAT, Inc.**  
 9750 CONKLIN RD.  
 CINCINNATI, OHIO 45242

Editorial



## The Peripheral Computer

Not long ago at the annual Society for Information Display symposium, presiding General Chairman Herb Hendrickson, whom we have long valued as friend and colleague, made a remarkable observation. In his opening statement he noted that perhaps a decade ago displays were considered peripheral to the computer, whereas today the computer is a display peripheral.

Although presumably his statement was principally made in jest, it merits serious consideration. All the data processing capability in the world is of little value if the man-machine synapse cannot be bridged. Application, of course, is instrumental in dictating just how effectively this interface will operate. Other matters aside, however, the data processor merely performs a large number of binary manipulations at unimaginable speeds and delivers the results for human consumption. Since the machine comprehends man through his display/control devices, it follows quite naturally that the computer is indeed the peripheral. It is simply a case of correctly interpreting the music of the spheres.

Having come to the inevitable conclusion which Herb proclaimed without the slightest trepidation, what can we infer about the future of display systems science and engineering? Clearly, the big computer will not easily relinquish its claim to preeminence. An alliance is needed, and will most logically be achieved with the mini and micro computers which do not suffer from historical precedents. Thus we see the dawn of a new era in which, through the miracle of large-scale integration and ingenious systems engineering, man accompanied by his computing display will command, control and solve the most awesome universal problems besetting him today.

Do we hear guffaws from the rear aisles? Let those who doubt and whose imagination and vision are limited take heed and recall that near the turn of the century, as legend has it, the head of the Patent Office suggested that his department be closed because everything had already been invented.

R.L. Kuehn

# COMSTOC<sup>®</sup> papers and films. No hop, no skip, no jump.

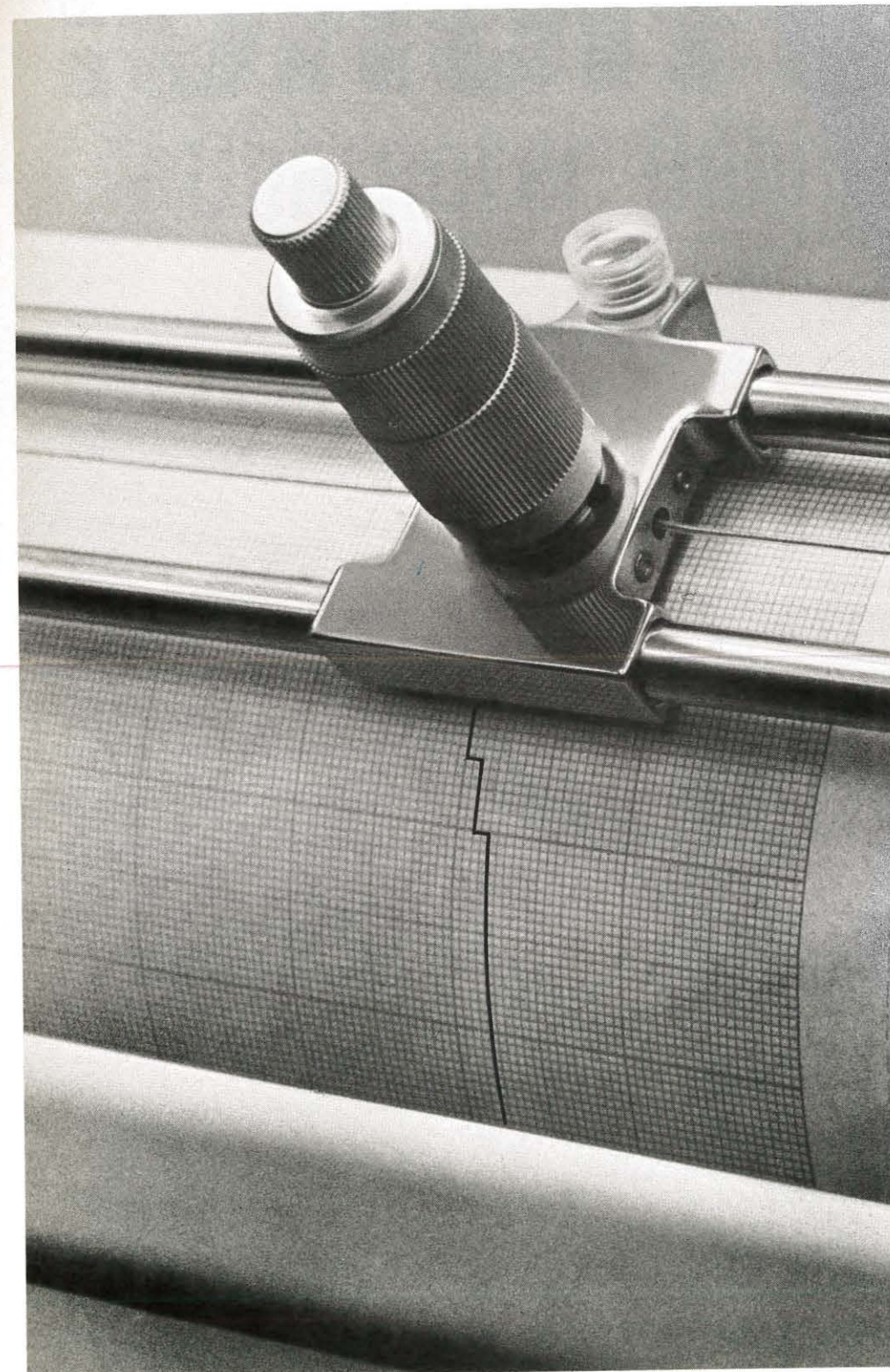

When you're doing computerized plotting, a skipping pen is the last thing you want.

Or lines that blot. Or dumbbell. Or ink that dries improperly. Or plotting that reproduces poorly.

K&E took care of all that. Developed Comstoc papers and films. With specially engineered surfaces, precision alignment, and precision inking.

End of trouble.

But we went further. We created all kinds of grid options—not just standard grids, but special grids, reverse side printing, matching colors, etc.

And then we formulated different grades of media for specific jobs. So we offer translucent paper, natural tracing paper, and transparentized tracing paper (with an engineered drafting surface for fast, clean erasures, or additional drafting requirements). As well as HERCULENE<sup>®</sup> films (for permanent records and sharp reproduction). And scribeable and peelable films for coordinatographs.

We'll also supply pens, inks, and pen cleaners—all specially designed to eliminate plotting problems.

And if you need special media, grids, or formats, we'll make them for you in 1, 2, 3, 4, or 5 colors. And repeats up to 54". Talk to your K&E representative. Or contact Keuffel & Esser Co., 20 Whippany Road, Morristown, N.J. 07960.

KEUFFEL & ESSER CO.





# IT'S HERE!

**It's the A280A, the first 2-track, dual gap read-after-write cassette head with its own integral precision mounting surface.**

The model A280A is a high-quality, data entry magnetic tape head that offers dependable read or write capabilities for virtually any application where cassette equipment is used for digital information.

It is ideally suited for use with peripheral equipment such as remote I/O terminals. The

precision-mount feature offers the advantages of saving assembly time because the head is precision machined and requires no adjustment.

The no-adjustment feature saves time and money if field replacement is necessary. Heads are supplied with long-life precision guides to insure proper tracking of the cassette tape.

Drop us a line or call us, and we'll rush you the specs. They make good reading.



Arvin Magnetics

A Division of Arvin Industries, Inc.  
6950 Washington Avenue South  
Eden Prairie, Minnesota 55343  
(612) 941-6700 TWX 910-576-2774

**High-quality magnetic heads for the computer industry.**

## A Television Compatible Character Generator

S.N. BARON

### Introduction

The most widely used method of introducing titling into television programming is superimposition. Superimposition requires preprogram preparation of the desired titles and the utilization of a camera as a "Title-to-Video Converter." A real-time capability is required to present immediate information, especially in the broadcasting of news, sports and other special events. Ideally, a system should provide the title information in a TV compatible signal format without the need for a camera or other scan converters. Character generators previously available were designed primarily to make computer-generated characters compatible with the TV scan. CBS Laboratories undertook to design a system which would synthetically reproduce a graphic arts style character with sufficient resolution to be compatible with the superimposition technique (see Figure 1).

A review of basic TV titling requirements was conducted. The following criteria were selected as desirable in a system:

- The capability of providing both upper and lower case characters with as clear and defined a letter form as possible.
- The capability of providing more than one character size (see Figure 2).
- The capability of providing word-by-word color.
- Rapid access to a bulk random access memory for pre-storage of large quantities of titles and other alphanumeric information.
- A system which provides edging information (black outline) as well as character luminance.

Other functional capabilities which were defined as neces-

sary or desirable were tabs, automatic centering, vertical roll, horizontal crawl, controlled flashing of portions of the display and an electronic clock.

Previous TV-compatible character generators exhibited several undesirable characteristics:



Figure 1: The Vidifont supplies characters which are compatible with superimposition.

© 1972 by Information Display Publications Inc. All rights reserved. Reproduction in whole or in part without written permission is strictly prohibited.



ABRAHAM RIBICOFF

Abraham Ribicoff

ABRAHAM RIBICOFF

Figure 2: Various font sizes permit the structuring of the most appropriate title.

- The effective resolution was not detailed enough to permit the synthesis of the angles and curves necessary to produce quality characters.
- A standard character width was established for each system which compacted wide letters (M,W) and left uneven spacing where narrow letters (l) appeared, again compromising quality.
- A standard system character height limited to an upper case capability only.

#### Font Characteristics

Font design is dependent upon many factors. These include: form and stroke weight; character size relative to the reading distance; letter spacing and leading; and brightness and contrast between the type and its background. Control of these factors is comparatively simple when dealing with the printed page; the design and size of forms are determinable, and the viscosity of the ink, the absorption of the paper, and the reflectivity of the surface are all easily regulated. No such exact control is possible over the reproduction of type on a television screen. There is no guarantee as to the final performance of the receiver, even when the best techniques and optimum efforts to transmit a high-quality image are used. Widely varying reception conditions and badly tuned home receivers affect the quality of reproduction. To overcome what appears to be bad reception, receiver contrast and brightness are exaggerated. This situation only adds to the deterioration of the type font.

In television titling, the letter form itself becomes the light source. This results in "halation," a blooming or bleeding of light at all inside corners from acute angles to right angles and beyond. This light emission, which obliterates the information at the intersection of the letter strokes, is perhaps the most significant phenomenon affecting the acuity of type reproduction on the CRT face. The blooming becomes exaggerated when too heavy or too condensed a letter is used or the letter spacing is very close. The problem is lessened to a slight degree by the use of the negative (black) form of the letter. The negative form appears to have less weight and is usually made heavier (wider strokes) to compensate for this effect. At times poor focus causes a variation in brightness from blooming to excessive falloff.<sup>1</sup>

A major obstacle in developing and analyzing a particular font is resolving the difference between its aesthetic appearance on paper and its actual appearance when presented on a television screen. Even when an attempt is made to synthesize the characteristics of the phosphor, final evaluation must take place on the viewing screen. Synthetic (digital) font design must always stress trade-offs in character structure in order to reduce the total memory required without sacrificing character quality.

#### Digital Character Generator

One important advantage derived from the digital character generator is the lack of a requirement for including light traps in the character structure since they are an integral part of the digital structure itself. Another advantage results from the fine control of the video generator as referenced to the sync signals. Since character information is controlled by the sync references, there is no uneven scanning as is found with the traditional scanned super technique. In other words, the Kell factor is unity.

Conversely, the prime disadvantage of the digital character generator is that intersection points on each horizontal stroke must be coincident with a clock pulse edge. This situation limits the placement of intersections to be a structured grid pattern. This is the most important limiting function of other character generators. The Vidifont offers a distinct advantage by analyzing the intersections on a line-to-line basis instead of making reference to a fixed grid pattern matrix. The Vidifont pattern is based upon a 20 MHz grid rather than being limited to the 2½ MHz to 4 MHz grid implied by the video bandwidth of the system.

Research performed by Mitre for the Air Force Systems Command, Electronics Systems Division, Command Systems Computer and Display Division in 1963 and 1967 revealed that 12 TV resolution lines are the minimum beyond which the error rate in differentiating between characters becomes unacceptable.<sup>2,3</sup>

Allen S. Neal, an engineering psychologist at the IBM Advanced Systems Development Laboratory, Los Gatos, Calif., in looking into legibility requirements for educational television, concluded that character information must not have a bandwidth of less than 2½ MHz, and to be legible, a minimum character height of 15 lines per character. While a character



Figure 3: Vidifont News-36 font.

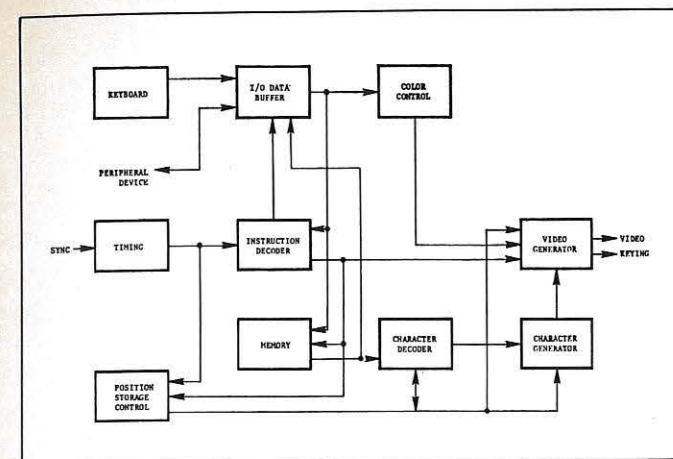

Figure 4: Vidifont Character Generator (block diagram).

display that utilizes 15 lines per character is acceptable, it can only be used when the viewing angle is kept small; consequently, the number of viewers is restricted. When the audience consists of more than one or two individuals, the preferred display should be about 30 lines per character. This figure implies that the maximum number of rows of characters which can be placed on the screen decreases from 16 rows with the 15-line character to eight rows with the 30-line character. The Society of Motion Picture and Television Engineers recommends as a minimum character height 4½% of the scanned height which is approximately 22 lines.<sup>4</sup>

From our own analysis of TV display needs, we independently arrived at the Vidifont two-font size requirement: 28 TV lines (quite close to the 30 recommended by Mr. Neal), and an 18-line font (slightly larger than the lower limit which he places on a display). The Vidifont proportional characters furnish the viewer with an additional reference for distinguishing between characters (see Figure 3).

#### System Functions

The Vidifont provides four basic functions: Interface; Timing and Control; Storage; and Character Generation, including edging (see Figure 4).

The Interface subsystem provides access to and from the Vidifont and its keyboard or peripheral devices. The Timing and Control subsystem accepts external sync commands from a suitable source, provides the basic timing, and generates the necessary internal signals to properly synchronize the characters generated with the display. Character and instruction information is stored in dynamic recirculating MOS shift registers.

Character information is provided by braided wire core Read Only Memories (ROM). The contents of these memories constitute the video information at logic signal levels. This information is fed to the Timing and Control section to be composed into a composite video signal.

The space occupied by a character in the display is a function of the character video. Each character is referenced to the end of the previous character providing a proportional display.

A Cursor Generator is provided for generating the Cursor in conjunction with the characters. Edging information is contained within the Character Generator ROM aided by a digital differentiator to provide a keying signal which surrounds the character with a black edge. Color information, flash codes, and other control codes are inserted in the Memory in the spaces between words. The coded information is carried as a three-bit code stored in the register.

#### Interface

The Interface provides access to and from the basic Vidifont and its keyboard and peripheral devices. The subsystem contains an Input Data Buffer which multiplexes between the data lines coming from the keyboard or the data lines coming from the peripheral devices. The Input Data Buffer is sampled to detect whether the information stored constitutes character information or instructions. If an instruction is detected, it is immediately applied to the Instruction Decoder, which decodes the commands and provides control of the required sequence.

Instructions decoded are cursor control for positioning, Delete and Erase instructions for modification of the character display, color codes, flash code and other instructions necessary to operate the various options. Color information, flash codes and other control codes are inserted in the Memory in the spaces between words. Color information is carried as a three-bit code stored in a register. The code controls the RGB content of the succeeding characters until altered. Therefore, the three primary colors, three secondary colors and white can be generated. Flash is a special code which, when detected, blinks all characters on the row until a space code is detected. This allows for word-by-word blink control. The Interface subsystem also provides Data Request Control circuits and External File Control circuits which provide commands for peripheral devices. An Interface Memory provides an auxiliary row of Memory, which is utilized as an Input and Output Buffer when the external storage devices have a duty cycle limitation which is incompatible with the basic Vidifont.

#### Timing and Control

The Timing and Control subsystem provides the basic timing and generates the necessary internal command lines and instructions to properly synchronize the characters generated with the total display, provides proper format of video output and provides basic timing comparisons. The Timing and Control subsystem accepts external sync commands from a suitable source and provides internal Horizontal Drive, (H); Vertical Drive, (V); and the basic 20 MHz character clock.

The Sequence Control generates a series of commands for Character Generation Read Request, Character Decoder Read Request, Loading Shift Registers (LSR), a two-phase clock necessary to control the memories, and the various storage strobe commands for loading the Input and Output Buffers, the File Buffers, etc.

The Position Controls provide Tab Storage and Control, a Position Counter for detecting the actual horizontal position of the raster scan, the Automatic Horizontal Position Counter for detecting scan position with respect to character position for proportional spacing, and the centering controls, arithmetic units and other repositioning control mechanisms used in automatic centering and for tab control.

Two row counters are provided: the Automatic Row Counter whose timing is controlled by the sync commands, and a Manual Row Counter (an up-down counter) controlled by the various operator instructions processed by the Vidifont through the Interface from either the keyboard or peripheral devices. When the position placed in the Manual Row Counter equals the actual position of the display with respect to the raster, a signal is generated for use in the loading of data. Two Horizontal Position Counters are also provided: the Manual Horizontal Position Counter, controlled by the various operator instructions and the Automatic Horizontal Position Counter.



ter which is controlled by the Spacer Detector. The Spacer Detector provides instructions as to updating of character information.

#### Storage

The third subsystem is the Memory itself. The Memory consists of circulating shift registers with eight bits of character storage provided per character word, up to 50 character words permitted per row, and 12 or 16 rows of complete storage depending on the system configuration. The Memory subsystem contains an Input Buffer Stream Select circuitry which allows either information presently contained in the system to be recirculated, or insertion of new information at the proper time; the necessary clock drivers to drive these recirculating shift registers; the memory devices themselves; and a Memory Output Buffer and Multiplexer which, under control of the Automatic Row Counter, selects the specific row of display for presentation to the Character Generator. A Memory Input Control, guided by the Manual Row Counter, selects the row to be inserted. A Row Compare Command from the Row Counter provides the instruction to actually load a specific character word into the Memory. By utilization of special controls, instructions can also be stored in the recirculating Memory, transferred through the Interface card's Auxiliary Buffer to the peripheral devices, and then returned so that complete display information, including format controls, can be transferred out of the Vidifont to the peripheral storage, and returned as required.

#### Character Generation

The space occupied by a character is a function of the character video. When the video information for the character is completed, the next character is addressed. Each character is, therefore, referenced to the end of the previous character,



Figure 5: Character edging information is provided automatically, negating the need for additional edge generating equipment.

providing a proportional display, such as that provided in all quality typesetting and executive grade typewriters.

Line selection commands are fed to the Character Decoder along with the stored character word. These control the Character Decoder Input Buffer which provide an address to the Character Decoder Memory. The Character Decoder Memory generates an 8-bit data word which is fed to the Character Decoder Output Buffer. The Character Decoder Buffer Word gives the address of the stroke which has to be generated. This information is then strobed into the Character Generator Input Buffer by a Character Generator Read Request command. This command selects an address in the actual Character Generator which provides data to its Output Buffer.

Character information is provided by a braided wire core ROM. The cores (utilized as transformers) are mounted on a plane, one core per word bit. A set of wires is woven in and around the cores establishing the logic pattern. When the wire is utilized as the primary winding of the core, a logic one is implied. If the wire does not pass through the core, a logic zero is implied. A second set of wires, constituting the transformer secondary winding are utilized as sense lines. When a control wire (primary) is activated, the proper output word appears at the buffer. The braided ROM offers the following advantages when viewed from this application: (1) It is field repairable by hand weaving a new wire into the braid and/or clipping out undesired wires. (2) The cost of producing custom units (special fonts) is approximately one-tenth the cost of producing a custom font utilizing either semiconductor ROM's or discrete logic.

A Cursor Generator is also provided for generating the Cursor in conjunction with the characters. The Cursor indicates the present contents of the Manual Position Counters.

Edging information is contained within the ROM aided by a digital differentiator to provide a keying signal which surrounds the character with a black edge. The Vidifont Keyer or Edger is substantially different from the technique used by others in the field. The standard technique for generating character edging involves delaying the character information by two lines, comparing the character information directly with the information contained on the scanning line above and below it, and if a difference is detected, generating a keying or edging signal. The Vidifont technique is to include the keying or edging signal as part of the memory information (see Figure

Continued on page 30



Figure 6: Vidifont provides a balanced set of capabilities designed to permit information display with a minimum amount of observer error.

## Describe the industrial & military CRT you need. Westinghouse will build it.

We'll even start off by assigning a design/application engineer to assist you. He'll give you the facts on brightness, contrast, resolution, and the other factors you'll want to consider before the right tube can be built for you. Then, after you decide on a design, we'll build and test it, using the most stringent precision techniques in the industry.

The Westinghouse team, backed by over 400 vacuum electronics engineers, is ready to help you. For more information, write or phone Westinghouse Electronic Tube Division, Industrial & Military Department, Elmira, New York 14902. (607) 739-7951. Ask for brochure B-9474B.

You can be sure...if it's Westinghouse 

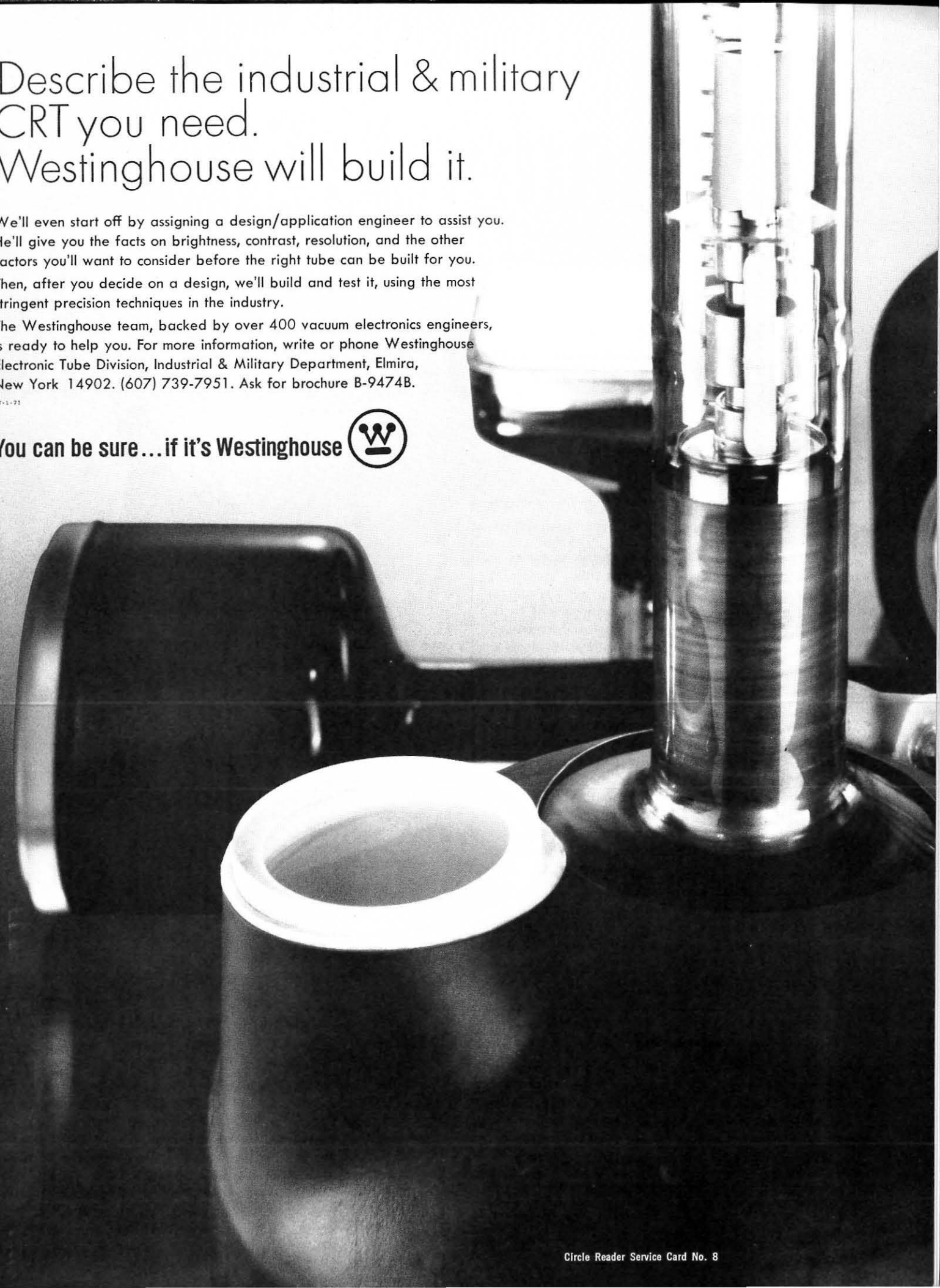



# Standard Theatre Stereoptics Without Glasses

## Part I

### Abstract

A new concept of geometry and suggested implementation is presented, which allows single point projection from existing theatre projection booths, and the utilization of the existing present seating arrangement (with changes required only in a special complexed screen and a projector using a single strip of continuously moving special film).

The picture is photographed with the aid of an extended array of electronic imaging camera tubes, whose signals are gathered in a nearby mobile processing truck, and the total information is recorded on a single film in real time. A positive copy of this film is used by a special stationary high speed projector to project the 3-D picture in a standard theatre. The information is time and space multiplexed to satisfy each person in the theatre with a separate perspective for his point of view. The field of view available to the audience is  $180^\circ$ .

The screen can be as large, or larger, than conventional wide screens, and is constructed of vertically dispersive direct reflective mirror type full screen height elements which are multi-faceted and rotate at a slow constant speed. These elements are pre-set in their phase relationship only once during the projection equipment set up and alignment procedure.

### Introduction

Since the publication of an article in the July/August 1968 and September/October 1968 editions of *Information Display* entitled "True Stereoscopic Movie System without Glasses" (Parts I and II respectively), the writer has tried to circumvent some of the problems presented by that system.

The article described a 3-D movie system, referred to here

© 1972 by Information Display Publications Inc. All rights reserved. Reproduction in whole or in part without written permission is strictly prohibited.

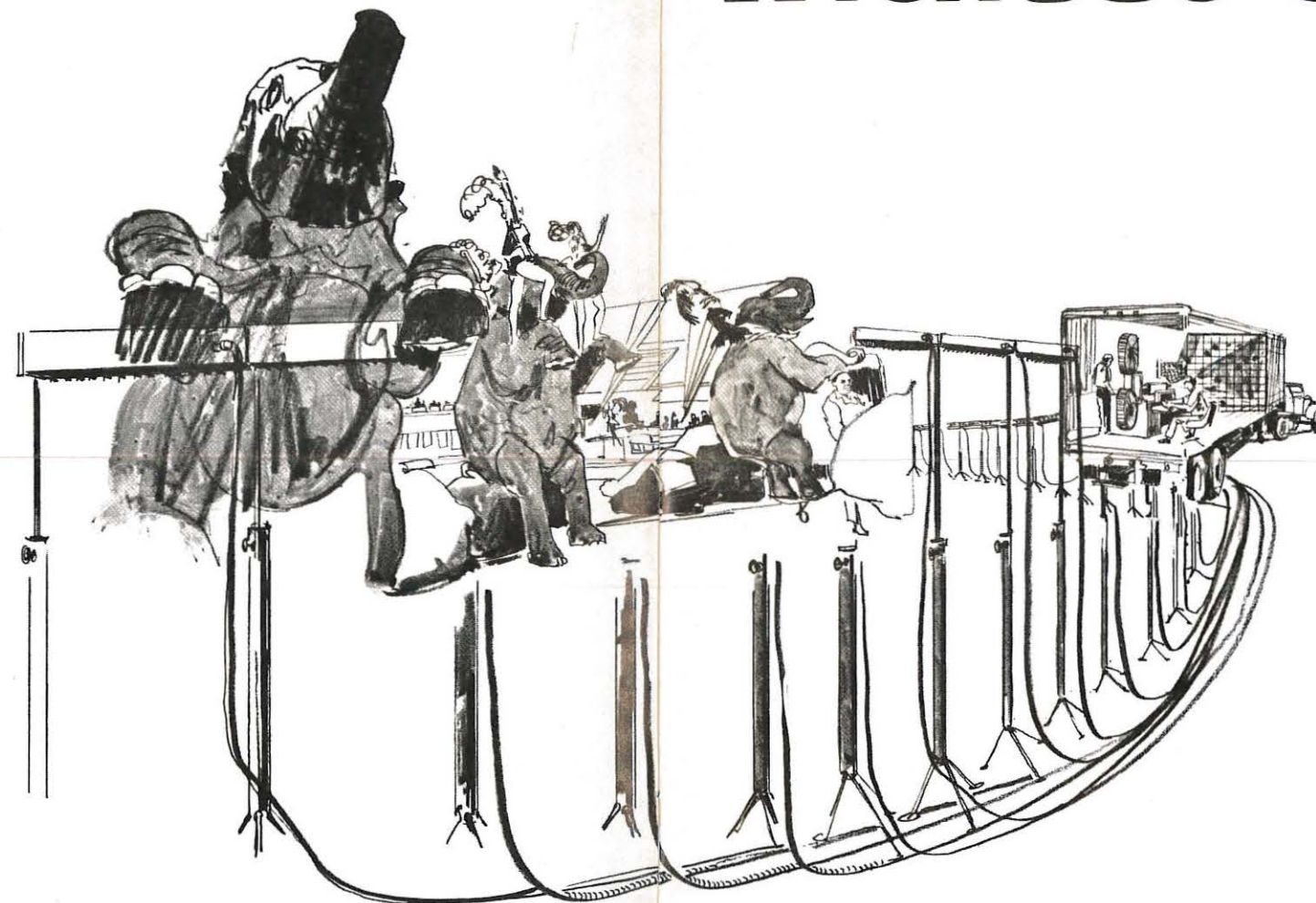

Artist's concept of wide screen stereoscopic capture system.

as the "old system," in which the capture equipment consisted of a 100 ft arc of 1500 pinholes, which were uncovered sequentially to expose 10 sets of horizontally moving spherical lenticular filmstrips. The filmstrip's movement and exposure were synchronized by a central control system. The resultant film was specially processed for centralized projection. In the theatre (which had to be specially constructed to handle the required geometry of the proposed system), a centralized projection booth was located at the center of curvature of a cylin-

ROBERT B. COLLENDER

scene in true stereoscopic vision. The audience would see the scene reproduced as through a large bay window (100 ft wide and 50 ft high).

The "new" improved system to be discussed in this paper, theoretically presents the same results as the old system described above, but without some of the obvious problems.

The old system required a special theatre with high overhead projection. The new system can use the geometry of a standard theatre without changing seats or the projection booth. The projection equipment of the old system needed to rotate about a central projection source lamp at 2.7 rps and contain three films and nine projection lenses. The new system uses a stationary projector with one filmstrip and a single stationary projection lens.

In the old system, 10 spherical lenticular horizontally moving films were required in the capture equipment. 1500 pinholes arranged over a 100 ft arc provided exposure of the film to the scene captured. The films were then sent to a special processing lab where 1500 vidicons, switching-logic and monitors, were required to convert the 10 filmstrips to three filmstrips compatible with centralized projection.

The new system uses 722 electronic imaging cameras in the capture equipment which relay the pictures, in a special sequence, to an "on the spot" processing truck which receives the closed circuit TV pictures and operates on them with special equipment to process — in real time — a single positive transparency film which is ready for projection in the theatres. The expression "electronic imaging cameras" is used in preference to "vidicons," as the requirement of resolution and scanning speeds are somewhat above conventional state of the art closed circuit TV equipment. The requirements will be stated in this paper. It is felt that all of the components necessary to realize total practicality in the proposed system of this paper, will be available in the electronics industry within a few years.

The 722 electronic imaging cameras are assembled and appropriately divided into 48 prefabricated cells containing approximately 15 cameras/cell.

The truck processor does not require the use of vidicons, and the processing equipment is relatively simple compared to the old processor.

The old system required a continuous processing time of 25

drical screen and stationary electronically controlled shutter selector. The pictures were released to the screen in a cyclic scanning time-multiplexed sequential overlap fashion as they were rapidly swept over the semispecularly reflective screen. In step with the sweeping myriad of pictures, the electronically operating shutter system, some 50 ft in front of the screen, forced each eye in the theatre to see an appropriate perspective for its particular position. Because of this, each person in the theatre would theoretically see a "different view" of the



days for a 1½ hour motion picture. The new system works on a real time basis (e.g. a 1½ hour movie requires 1½ hours to process and the pictures are processed while they are being captured).

In both the old and new systems, the use of spherical lenticular film is recommended, as fine time resolution capture results through the use of image dissection techniques (e.g. 722 times finer time resolution than standard 2-D pictures). This is accomplished by increasing the film transit rate through the processor-camera and theatre projector, increasing the film format size, and matching the spatial resolution of the final picture to the view distances of the observers in the theatre.

The old system required an electronically controlled shutter about 50 ft in front of the screen. This shutter tended to limit the observer's viewing angle and to generate vertical bars in the picture at extreme off-axis viewing angles. It also required that the projected light reflected from the screen be directed to the slit (which was open at any given time) to avoid extreme light losses. A method for accomplishing this direction was not suggested. The new system does not require a shutter selector in front of the screen or any other obstruction between the screen and the observers. The new system directs reflected scene image light from vertical picture elements to all the eyes

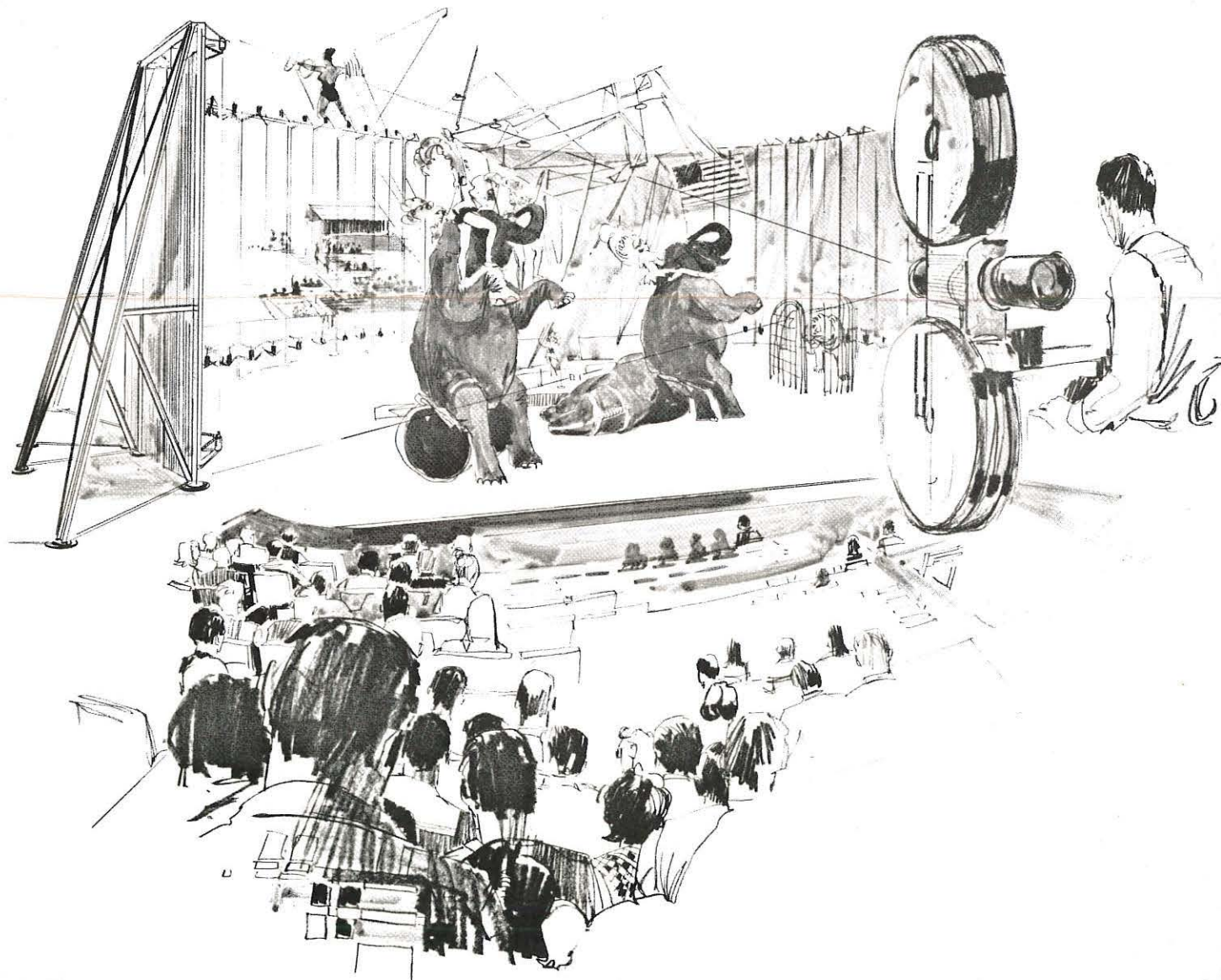

Artist's concept of wide screen standard theatre stereoscopic playback system without the need for special glasses.

in the theatre in a time/space multiplexed fashion through the use of rotating element screen reflectors which are timed and phased with the projected picture. The result is a correct stereoscopic picture presented to each observer in the audience area.

### Basic Geometry and Theory of Operation

In the article referred to in the introduction, a discussion was presented relative to "Scene Image Compression and Expansion Compromises," resulting from the capture and playback of horizontal parallax only. The vertical parallax was shown to be of no importance to stationary observers. This analysis led to the recommendation of a cylindrical rather than a spherical 3-D system with resultant total complexity reduced to the square root of that found in the spherical system.

Space images appearing in a 1:1 cylindrical system (i.e. where the capture and playback equipment are equal in size) will be subtended by angles in a horizontal plane measured at the eye, which are identical for both the capture and playback systems. However, the vertical angles subtended by the space images at the eye will not be the same in the capture and playback, except at the relative capture points superimposed

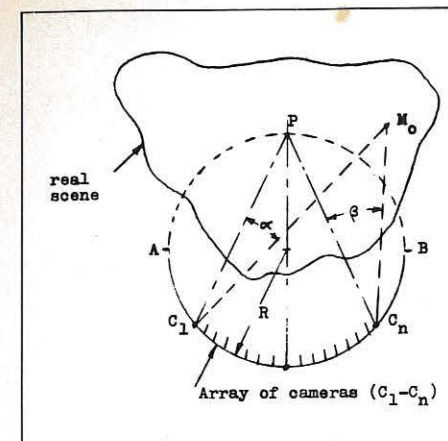

Figure 1: General capture.

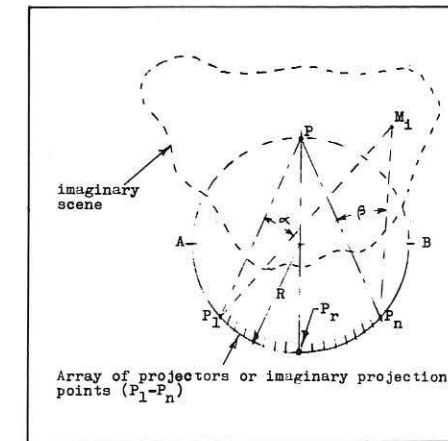

Figure 2: General playback.

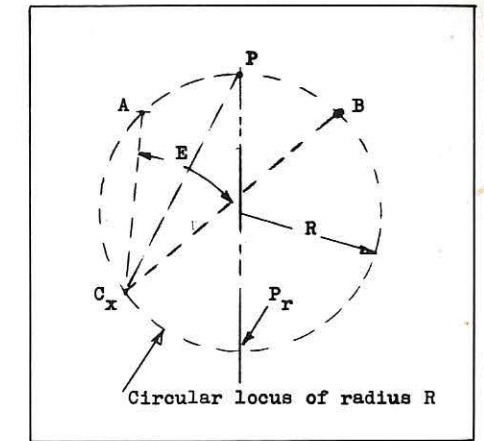

Figure 3: Plan view of capture system with arbitrary camera  $C_x$ .

on the effective projection points. The amount of deviation from a true condition (experienced in a spherical system) can be made minimal by adjusting the view-distance limits. The maximum view-distance limits should also be fixed to limit the quantity of images required for faithful stereoscopic presentation to the rear seats in the theatre. Since the amount of shrinkage, expansion and resulting compromises were studied in the previous *Information Display* articles, they will not be repeated here. In any case, the relative location of space images to real objects is maintained, and construction diagrams depicting the basis of the cylindrical 3-D systems can be shown.

Figure 1 shows a series of capture points ( $C_1 - C_n$ ) all directed toward a fixed point (i.e. aiming point "P") in space and formed in a circular locus which includes the "aiming point." Figure 2 shows the same capture points turned into projection points.

In order to understand the cylindrical capture system, the variations in vertical angles subtended by scene images at the observer's eye (considering all the capture and viewing parameters) are not discussed here, and therefore accurate plan views of the capture and playback systems can be analyzed.

In a very general way, the locus of the cameras should equal the locus of the projectors and the focal lengths of each should also be equal. For simplicity and convenience, the locus is made circular, although it could theoretically be any shape. The cameras and projectors are pointed at the aiming point P for very important reasons to be explained. It is assumed that the capture and playback window widths will be  $\overline{APB}$ .

The reader can now imagine a "roving eye" moving through the capture system in such a way that sight lines drawn through points A and B and the eye position always intersect somewhere in the arc of cameras (e.g.  $C_1 - C_n$ ) or a portion of  $\overline{APB}$  can be viewed with sight lines drawn through  $C_1$  and  $C_n$ . The roving eye could move on the concaved or the convex side of the camera array arc.

The quantity of capture points required was also discussed in the earlier article, and resulted in a separation equal to or less than the average human interocular separation (or about 2.5 in., assuming that the projector arc array is located in the position of the farthest spectators). A roving eye in the playback system would be forced to see the same real scene captured in a synthetic space image, if the path of light rays from all points in the scene are returned to the projectors. Figures 1 and 2 show an arbitrary point  $M_o$  in the real scene and  $M_i$  in the spatial reconstruction. This point is observed by camera  $C_1$  at  $\alpha$  degrees to the right and by camera  $C_n$  at  $\beta$  degrees to the right. If projectors  $P_1$  and  $P_n$  release  $M_i$  at these respective

angles, and each receive the  $M_i$  intensity and color modulated projection reflective light at these angles, then the viewing conditions in the capture system for eyes within the bounds specified above, will be identical to the viewing conditions of the original scene, if all of the cameras and projectors in the arc array react in this manner.

The quantity of capture and projection points for a standard size theatre, with radius R in Figure 2 equal to 50 ft, would be approximately 722.

With advanced developments in electronic imaging cameras which are similar to vidicons but capable of 5000 scan lines (vertical) per image format width per 10 ms, it is easily envisioned that the 722 capture points could provide parallel information to a local real time processing mobile unit (truck). However, cost and practicality of an equal quantity of projection points is completely prohibitive. These factors were also discussed in the previous article.

The new system to be discussed in this paper will only require a single projector located at  $P_r$  in Figure 2. The location of  $P_r$  need not coincide with the projection arc, but could be in front, behind or off to the side with suitable distortion compensation. However, it is proposed that the imaginary circle constructed in any existing theatre today, pass through the existing projector location in the projection booth, and include the new screen to be proposed in this paper which will occupy the position of arc  $\overline{APB}$  as shown in Figure 2.

The size of the space images relative to the real objects are in direct proportion to the size of the playback circle relative to the capture circle. It is anticipated that the variations in projection circle sizes with different existing theatres will cause a negligible sensation in space image dwarfism or giantism as a result of departure from the ideal 1:1 relationship.

### Theory and Geometry of Capture System

Figure 3 shows a plan view of the capture system with an arbitrary camera  $C_x$  pointed at P on the circle, and having a field angle of E degrees intercepting points A and B on the circle. It will be shown in the mathematical analysis section that if  $C_x$  moves anywhere on the circle while pointing toward P and maintaining the same field angle E, that the circle intercepts will always be A and B.

The actual capture equipment will consist of 722 individual electronic imaging cameras at fixed capture locations along the circular locus and each camera will be pointed at P, with an alignment accuracy discussed in the system alignment requirements section of this paper.



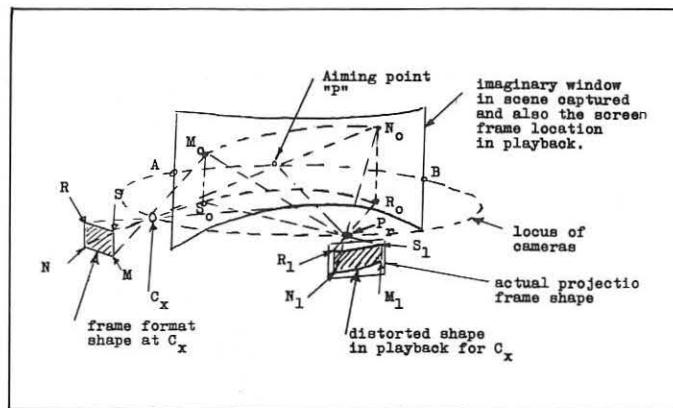

Figure 4: Composite capture/playback perspective showing distorted playback format for off-centered capture point  $C_x$ .

The portion of the circle's arc (i.e.  $\widehat{AB}$ ) in Figure 3, shall be designated the imaginary screen as viewed from a plan view. The points A, P and B are not real, but are imaginary points on which to analyze the system operation. Point P may be a physical reference point used during capture set up only.

All 722 capture points are recording the scene through the imaginary  $\widehat{AB}$  window at a 24 Hz rate, so as to avoid flicker when projector images release the corresponding scenes at a 722 x 24 Hz rate resulting in an observable frame rate of 24 Hz.

This paper describes the system as though it causes a 24 Hz refresh rate to the eye which is only one-half the rate of standard theatre projection. In standard theatres, the film frame is stationary while it is shuttered twice. This 3-D system does not allow direct shuttering, but an effective interlace is employed to bring the flicker rate to 48 Hz. The odd cameras are scanned in 1/48 s and then the even cameras at the same rate. There is no bandwidth increase. In the projection, the multifacet reflective screen elements rotate at 6 rps instead of 3 rps. The description in this paper stays with the 24 Hz only because of ease of explanation in not having to think about an interlace system.

In order for the angle E to be common to all capture points, the camera format sizes are all identical and all of the objective lens focal lengths are equal.

An earlier discussion suggested that a single projector would release each of these captured scenes from a fixed point (e.g.

$P_r$  as in Figure 3). The projector horizontal angles for all camera positions are equal as the frame format width is spanned at each position. However, the projector vertical angles, as mentioned before, are not equal for all camera positions, and this variation will be corrected for in the processor electronically and will be discussed later in this paper.

Figure 4 shows a composite capture/playback perspective drawing to illustrate the tendency for distortion especially for off-centered capture points.

When off-centered capture point  $C_x$  looks out into the scene, its sight line limits imposed by the camera frame size and objective lens focal length, intersect the imaginary cylindrical window which passes through  $\widehat{APB}$  in the plan view. The camera frame format corner reference points (R, S, M and N) intersect the imaginary window in the corresponding points  $R_o, S_o, M_o$  and  $N_o$  which forms a distorted shape on the window.

If the imaginary cylindrical window is thought of as the real screen in the playback, then the projector located at  $P_r$  would require a distorted shape (e.g.  $R_1, S_1, M_1$  and  $N_1$ ) formed on the film plane in order to restore the intercept points  $R_o, S_o, M_o$  and  $N_o$  in the identical spots of the real screen as they appeared on the imaginary window.

The projection geometry section will discuss a special elemental screen which selectively diverts the incident projection images on the screen back to their relative capture locations (e.g. in this case, back to  $C_x$  and only  $C_x$ . The  $C_x$  captured information shall not be visible from any other position along the circular capture locus).

### Theory and Geometry of Playback System

The projection (or playback) system can most easily be analyzed if a 1:1 size relationship is taken between the capture and the playback systems. The objective of the playback system is to reproduce all of the scene's light rays incident toward each of the 722 cameras, and cause them to again be incident toward the same relative camera locations superimposed upon the playback geometry (taken from a plan view).

The playback system will have a single projection point location at  $P_r$  in Figure 5 and  $P_r$  will project each of the 722 pictures (left to right) in sequence, covering the entire sequence of 722 complete camera scenes in 1/24 s.

The time is frozen at the frame captured by camera  $C_x$ , and

the entire  $C_x$  picture is projected from projector  $P_r$  to the screen  $\widehat{APB}$  with an included angle E. Note that the original capture at  $C_x$  also included angle E (from Figure 3) and encompassed the same arc  $\widehat{APB}$  on the imaginary window frame. All cameras and projector have the same focal length lenses and frame format width.

The entire bundle of rays incident on the screen  $\widehat{APB}$  can be easily analyzed from a plan view. The elevation view would show any light ray striking the screen at any elevation, spreading vertically to be visible over the auditorium from the near to the far seats. This vertical dispersion will be discussed in the implementation of the playback equipment section.

The screen may be thought of as made of a few thousand vertical screen elements (discussed in detail in the playback implementation section), each of which contains eight horizontally reflective and vertically dispersive facets that slowly rotate continuously in sync with the film transit through the projector.

The effect of the horizontally reflective elements is to reflect any arbitrary ray projected from  $P_r$  to any desired point along the arc  $\widehat{C_{xi}P_rC_{ni}}$  (e.g. point X on the screen may direct its light rays received in a vertical plane passing through X, to  $C_{xi}$  as shown in Figure 5, or to any other point along the arc). However, if all of the screen points shown (e.g. A, P, X and B) are mechanically phased to reflect the  $C_x$  projected frame from  $P_r$ , then the four rays will reflect from these screen elements to the imaginary point  $C_{xi}$ . Hence,  $C_{xi}$  will pick up as many rays as there are vertical screen elements to reflect the projected rays. An eye located at  $C_{xi}$  would see the scene as photographed from the original camera located at  $C_x$ .

It can be shown by geometry (reference the mathematical analysis section of this paper), that the angle subtended anywhere on a circle by any arbitrary two points on the same circle, is always equal. In Figure 5, the angle E is shown as it is subtended by  $\widehat{AB}$ . Also, angle  $\psi$  is equal to A, P, X and B, as they are all subtended by a constant arc distance  $\widehat{C_{xi}C_{ni}}$ . Because these angles are all equal, it means that the rotation angle of each elemental screen reflector at A, P, X and B is equal to  $\psi/2$  in order to divert the complete picture from  $C_{xi}$  to  $C_{ni}$ . Note the law here that the deviation angle of a ray incident on a rotating mirror equals twice the angle of rotation of the mirror. During this transition, the projection frames released from  $P_r$  cycle through the 722 captured scenes and sequentially return them to their respective positions along the arc  $\widehat{C_{xi}C_{ni}}$ . This fact allows the few thousand screen rotating elements to be linked together and rotated at the same speed (namely 3 rps x 8 facets = 24 frames per second) and relative fixed phase relationship between one another.

The entire screen/projection system can initially be aligned by projecting the camera scene originally captured from the relative position of  $P_r$  and phasing each vertical element to reflect the entire scene into the projection booth. From this point on in the life of the theatre, it is only necessary to sync the screen prime mover with the film movement, which is accomplished by means of coded timing pulses recorded on the film. With this method, automatic phasing is accomplished, even though parts of the film have been spliced.

### Capture and Playback Integrated Geometry

The combined geometry of the capture and playback systems can be depicted to enhance the understanding of the total system operation where describing these systems separately may prove a bit confusing.

Figure 6 shows a "ray-a" traced from the light incident on the camera from an arbitrary point in the scene given any-

where in depth along the ray-a line, and then the reconstruction of ray-a during projection.

Camera  $C_x$ , with its optical axis aimed at point P, intercepts ray-a from a point in the scene which also intercepts point "X" on the imaginary window frame. In projection,  $P_r$  throws ray-a toward X on the vertically dispersive reflective element (explained in detail in the section on implementation of the playback system), which fans out at point X into a vertical plane containing points xy and z and the original camera position  $C_x$ . Therefore, the point X can be seen by an eye located anywhere in the  $xyz$  plane.

Figure 7 shows a line  $A_oB_o$  in front of the imaginary window and captured by a camera  $C_x$  on the right hand side of the projection position  $P_r$ . The image tracing is also shown for capture and playback to assure reproduction of the image of the line in the playback system.

In Figure 7,  $C_x$  is an arbitrary camera with its optical axis pointing toward P. Object  $A_oB_o$  is in the near field and is captured by  $C_x$  at  $A_1B_1$  on the sensitive surface of camera  $C_x$ . The plane determined by  $C_xA_oB_o$  is extended to the imaginary window at  $A_2B_2$ . Projector  $P_r$ , carrying picture  $\widehat{AB}$ , releases  $A_2B_2$  to the screen, and the reflective element is turned to reflect  $A_2B_2$  rays in a plane including  $C_x$ . This geometry is true for all possible positions of  $C_x$  while  $C_x$  is recording arbitrary objects in its field of view (e.g.  $\widehat{A_oB_o}$ ).

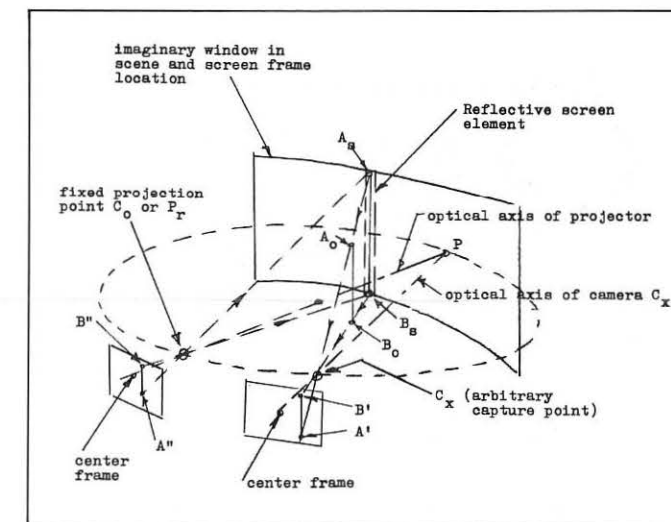

Figure 7: Composite capture/playback and the reproduction of a near object.

### Mathematics of the New 3-D System

Lines drawn from a chord's intercepts of a circle (points A and B in Figure 8) to intersect anywhere on the circle on one side of the chord, intersect with an included angle E. Figure 9 shows the geometric construction from which a mathematical analysis of the relationship stated in Figure 8 can be made. The problem is solved by starting with the assumption that the angle E is equal for all possible positions of P, and then showing that  $S = R$  in the figure and the locus of P then is a circle.

Mathematical proof of Figure 9:

$$x = R_1 \cos \beta - R \sin E$$

$$y = R_1 \sin \beta - R \cos E$$

$$\frac{R_1}{\sin(\beta + E)} = \frac{L}{\sin E} = \frac{2R \sin E}{\sin E} = 2R$$

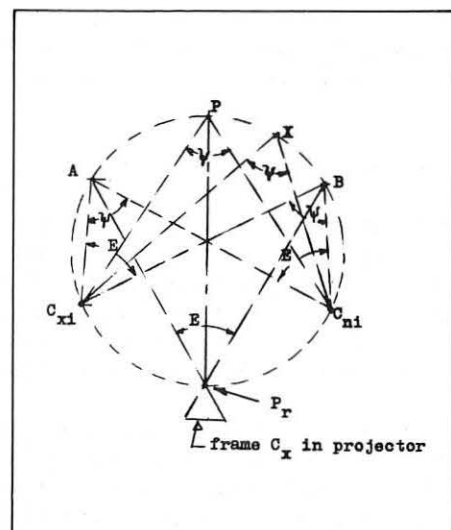

Figure 5: Projection system.

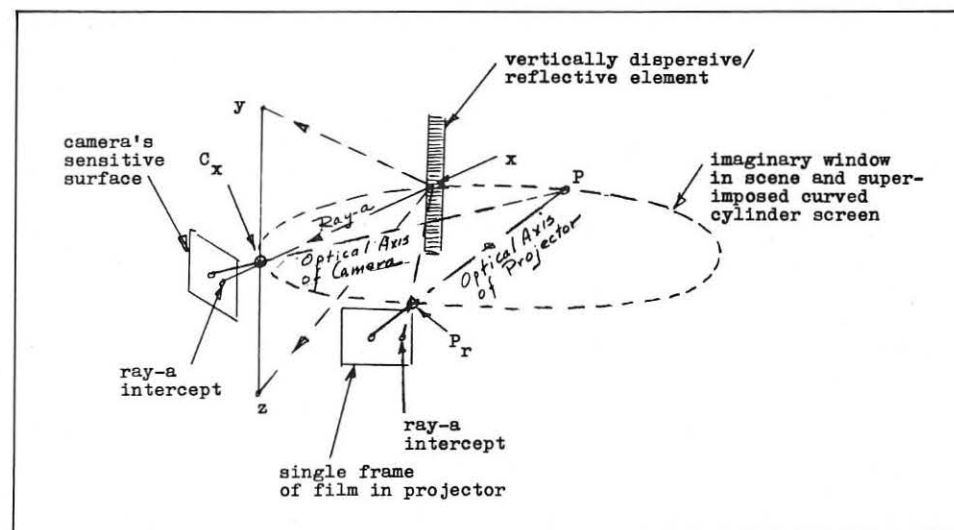

Figure 6: Explanation of capture and playback of an arbitrary "ray-a."



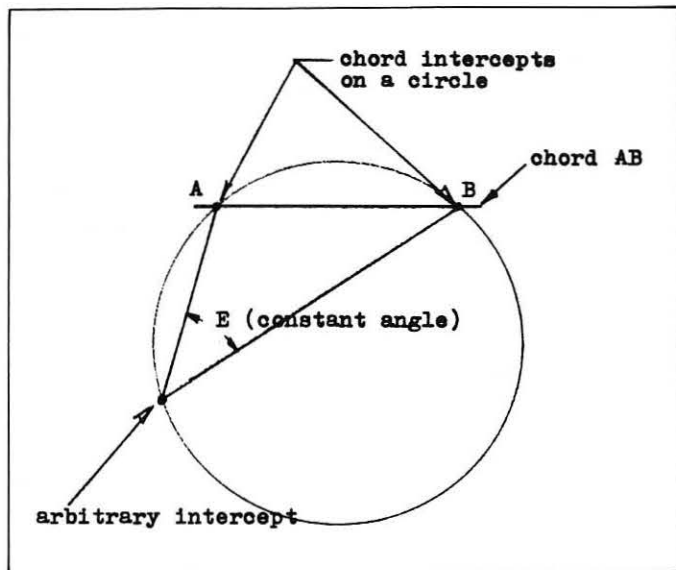

Figure 8: General geometric construction of capture/playback.

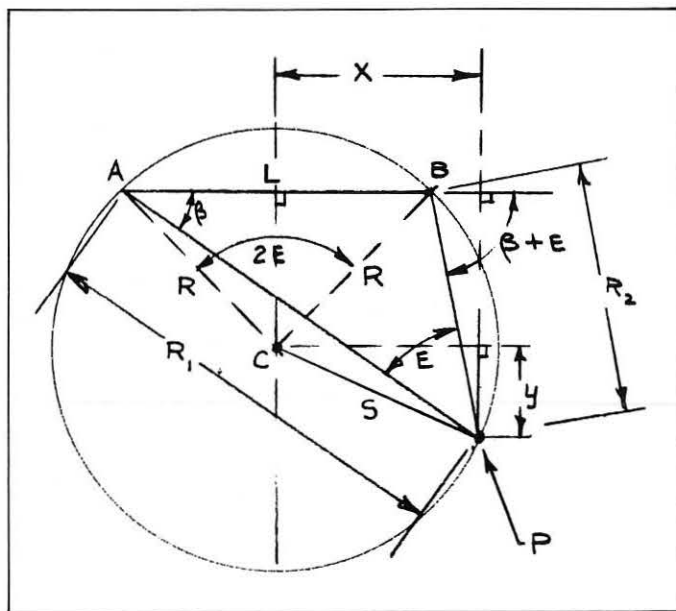

Figure 9: Mathematical proof that a circle of radius "R" passes through points A, B and P.

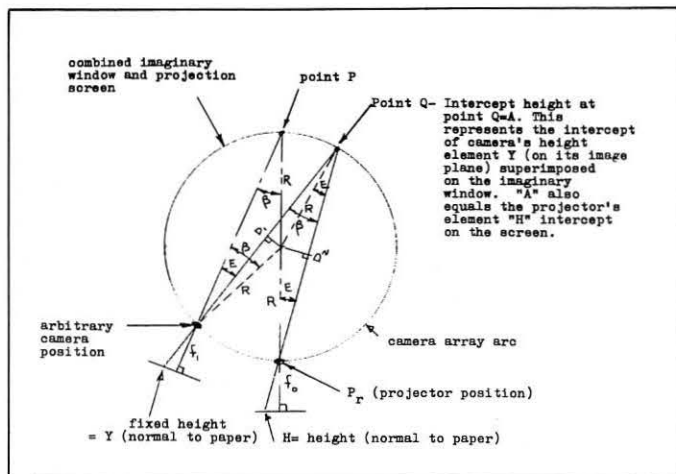

Figure 10: Effect of rectangular camera format complete utility on the format shape of the projected substitute images.

It can be shown that:

$$x^2 + y^2 = 4R^2 \sin^2 (\beta + E) - 4R^2 \sin^2 (\beta + E) + R^2$$

$$x^2 + y^2 = R^2$$

but from Figure 9,  $S^2 = x^2 + y^2$  also, therefore  $S = R$ , and it is proven that the locus of point P is a circle of radius R with center C.

#### Derivation of Projected Image Frame Format Shape

All of the 722 cameras (electronic imaging cameras) arranged around the capture arc have equal size sensitive surface areas where the scene images are focused. As these cameras, with equal focal length objective lenses and their optical axes all converging on the aiming point P (as in Figure 10), look out into the scene, the frame limits of each of their image planes intercepts the imaginary window previously explained. The imaginary window is shown in Figure 10 as having a plan view circular shape of radius R and passing through points P and Q. The projector located at point P<sub>r</sub> must release sequential pictures to a real screen located in exactly the same position as the imaginary window in the capture of the scene. These sequential picture frame formats must exactly superimpose the respective intercepts on the imaginary window/real screen combination.

Since each of the camera positions is oriented differently with reference to the window, it follows that the projection frame format shapes for each of the 722 camera positions is different. This variation only applies to the vertical planes, and not to the horizontal, as it has been proven that horizontal angle E is constant for all positions.

As described in more detail in the processor implementation section, the 722 camera scenes are rapidly scanned in a unique manner, allowing real time film recording of the 3-D events. An array of special monitor tubes is used in which a special function is imposed on one axis of each of the monitor deflection yokes. This imposed function corrects for this vertical angle variation causing sequential odd shaped frame formats to be recorded on special spherical lenticular film.

It can be shown from Figure 10 that,

$$H = \frac{f_o Y}{f_1} [\cos \beta + \sin \beta \tan E]$$

where Y is the fixed height of each of the camera frames, and H is the corresponding variable height of the corresponding projected frame from position P<sub>r</sub>.

It is of interest to note that the radius of the capture and playback systems does not influence the capture and playback image plane format shape geometry.

#### Capture System Implementation

The capture system consists of 722 electronic imaging cameras among 48 individual cells which are connected together to form a semicircle of 100 ft diameter. (The value of 100 ft was chosen to correspond with the average theatre projector to screen distance of 100 ft.)

Each cell is 3.14 ft long with a cross section of approximately 3 x 5 in., and is identified with a number from 1 to 48. The cells are not interchangeable as each cell (2 through 47) contains 15 prealigned electronic imaging cameras which point

to the previously defined aiming point P. Cells 1 and 48 each contain 16 electronic imaging cameras for a grand total of 722.

The quantity of 722 cameras is chosen from a study of the processor station and the quantity of normal interocular spacings that can be placed along a 100 ft diameter semicircle. The rationale for selecting this quantity is described in the next section (processor system implementation).

The cells are portable and are easily managed by a camera crew. The alignment procedure for the cells is discussed in the system alignment requirements section.

All 722 cameras used in the camera array utilize a common horizontal and vertical sync signal, and all of the deflection waveforms are identical in the camera tubes. The processor which is contained in the mobile unit shown in Figure 11, will interject the proper vertical scan line size onto the final 3-D

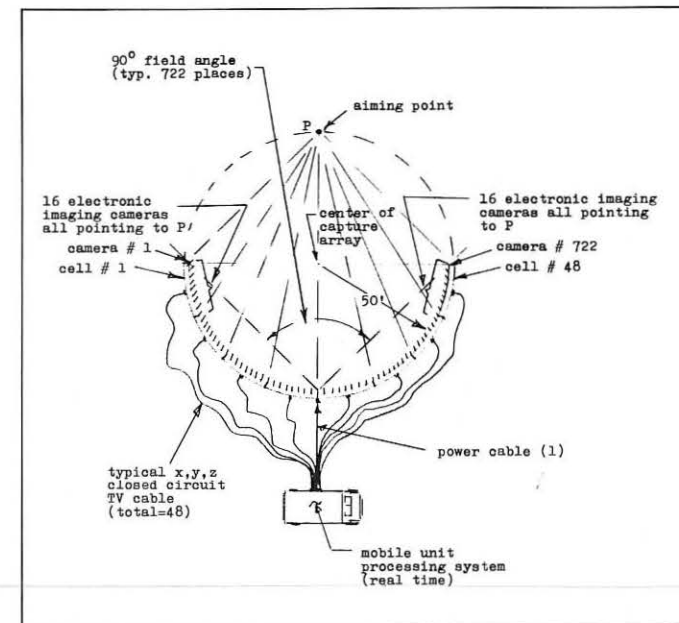

Figure 11: Plan view of capture/processor system.

recording of the scene to compensate for the off-axis camera positions with respect to the projector's axis (the need for this function has been described already in this paper).

Each cell will have 17 coaxial cables (e.g. 15 video z-axis cables for the 15 individual cameras, and sync pulses for the generation of horizontal and vertical deflection signals). Each cell will also have an input and output connector for power, which enters cell 24 with short leads from the mobile processor unit, and feeds to each cell in a serial manner. The reason for not applying the x and y sync signals in the same chain sequence as in the power system in order to conserve long cable runs, is because of the variable pulse delays that would result in each of the cells. Therefore, each of the cables servicing the 48 cells is of equal length, or about 100 ft long.

The coaxial cables proposed for this application were selected from data available through the National Wire and Cable Corp. Each cable has a diameter of 0.155 in. OD. When these cables are bundled in a jacket containing 17 cables, the overall diameter equals 0.75 in. The characteristic impedance is 95 Ω and the attenuation measured at a line transmission frequency of 150 MHz is about 6 dB over a cable length of 100 ft. 150 MHz is the expected high video frequency for a 24 Hz refresh rate using a 5000 line scan system at 1000 points per line and a 10% horizontal and vertical flyback time.

Figure 11 shows the plan view of the capture equipment as it connects to the mobile processing unit. In the figure, only

eight cells are shown for simplicity of illustration, to represent 48 cells total.

The separation between adjacent cameras equals 2.5 in., or the average interocular separation for observers in the theatre.

Each of the cameras would have a field angle of 90°, which would take full advantage of each camera's unobstructed field of view. Camera No. 1 and camera No. 722 would just be hidden at the extreme left and right frame positions, respectively, for each of the 722 perspectives of the scene captured.

Each of the cameras must provide a 5000 line scanned frame format. This is due to the required theatre resolution and the fact that the projector releases a complete panorama to the screen at any given frame time — 722 times per 1/24 s. This is different from the old 3-D system described in the previous *Information Display* article, where only a portion of the complete panorama was projected at any instant.

The electronic imaging camera frames will be scanned vertically since the distortion correction is applied only in the vertical scan direction. A vertical scan allows linear sweep waveforms and straight scan lines of varying lengths, instead of curved horizontal scan lines.

#### Bibliography

1. J.S. Chandler and J.J. DePalma, "High-Brightness Projection Screens with High Ambient Light Rejection," *Journal of AMPTE*, Vol. 77, Oct 1968, p 1012.
2. L.J. Krolak and D.J. Parker, "The Optical Tunnel — A Versatile Electro-Optical Tool," *Journal of SMPTE*, Vol. 72, Mar 1963, p 177.
3. J.S. Friedman, "History of Color Photography," Chapters 16, 17 and 18 (on lenticular film), Focal Press, New York. Reprint 1968, pp 214-272.
4. R.B. Collender, "True Stereoscopic Movie System Without Glasses — Part I," *Information Display*, Vol. 5, No. 4, July/Aug 1968, p 25.
5. R.B. Collender, "True Stereoscopic Movie System Without Glasses — Part II," *Information Display*, Vol. 5, No. 5, Sept/Oct 1968, p. 23.
6. Andrija Dvornik, Patent Specification 421,120 (British), "Method and Apparatus for the Production of Motion Pictures," Oct 12, 1932.
7. A.H. Pettis, "Distributed Plates Improve CRT Responses (to 250 MHz)," *Electronics World*, Nov 1969.

To be continued



Robert B. Collender received his B.S. degree in Electronic Engineering from the University of California at Los Angeles. He has spent 15 years in the aerospace and aircraft fields, mostly working on multiplexing and readout methods in ground support, airborne and space vehicles. In parallel, research and development with laboratory investigation of 3-D effects has been pursued. Early work (1949) involved 3-D drawing machines in an attempt to give more freedom of expression to artists. He is currently employed by Lockheed California Company in Burbank, California, as a design specialist assigned to an ASW Display Group where CRT multipurpose displays are designated with computer and special sensing equipment interfaces.



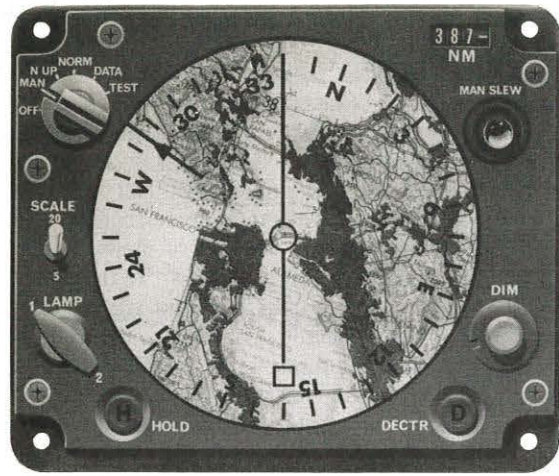

Our famous Projected Map System was one of the first major avionics systems to pass reliability demonstration and qualification testing. Now we're fully qualified and flying aboard the U.S. Air Force A-7D and U.S. Navy A-7E. We haven't forgotten the U.S. Army either. Our PMS is now part of the Army's Tactical Air Guidance System for helicopters.

Backed up by more than 50,000 flight hours, PMS is in action now helping to cut pilot workload to a minimum. It's boosting pilot confidence. Boosting mission flexibility, too. It even makes in-flight target reassignments easier.

All of which make our PMS the most effective interface between pilot and navigation system ever devised.

Just ask the pilots who fly the A-7 attack fighters. They wouldn't leave the deck without us.

For details on our PMS, write to: Avionics Marketing, Computing Devices of Canada Limited, P.O. Box 8508, Ottawa, Ontario, Canada K1G 3M9.

**Our Projected Map System is fully qualified for the A-7D/E.**

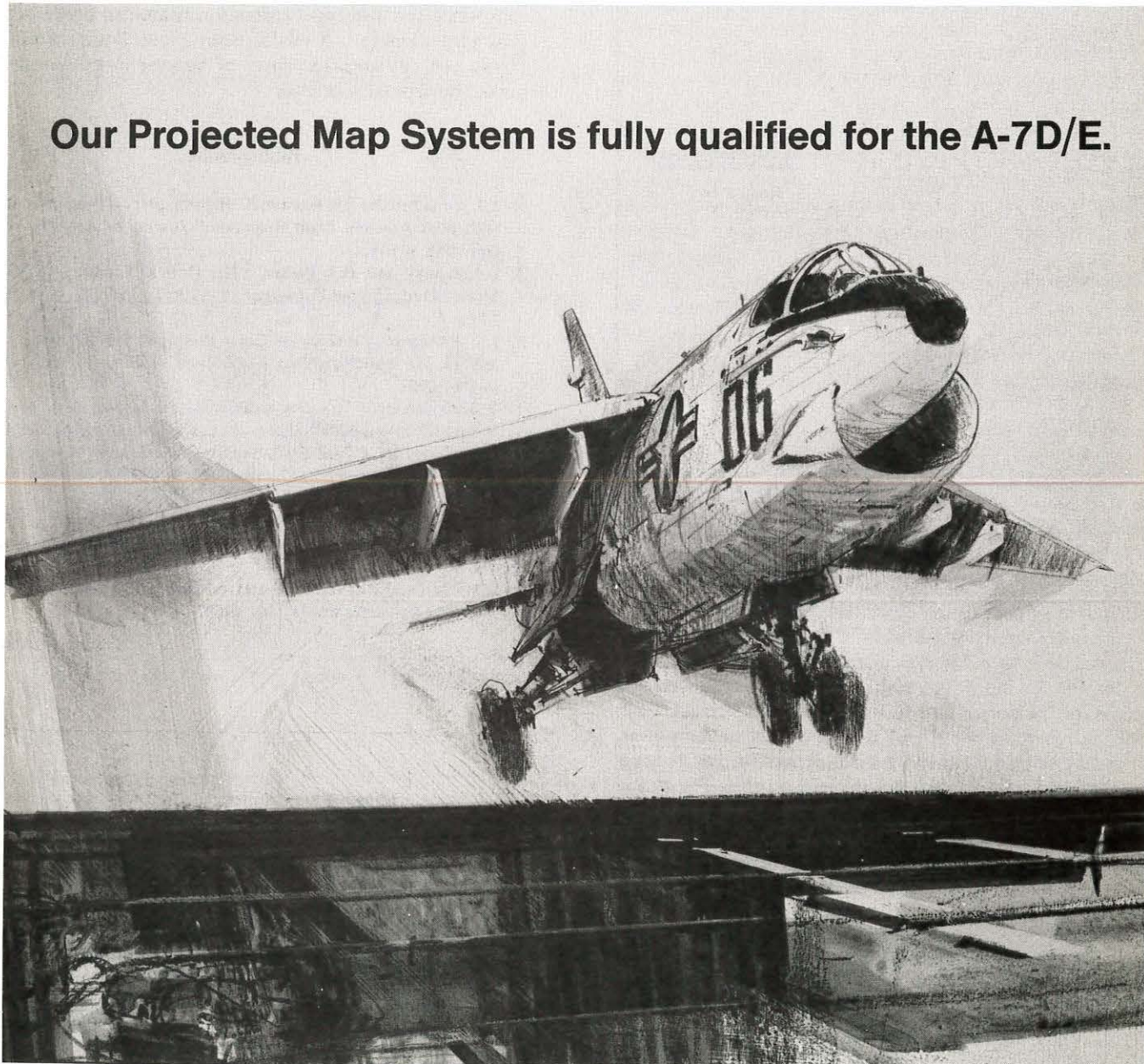

**Computing Devices  
of Canada Limited**  
a subsidiary of

**CONTROL DATA  
CORPORATION**

P.O. Box 508 • Ottawa 4 • Ontario • Canada

# CRT Write Rate VS Bandwidth Study

—ALFRED PLETZ Jr.—

## Introduction

The purpose of this study was to tie together three important parameters in a display system, namely: write rate, deflection system bandwidth and stroke written symbology appearance. In the past it has always been assumed that the above parameters are somehow related but it was not known in what manner. This report sheds a significant amount of light on this problem.

## Analysis

In the analysis, a second order control transfer function was used. The transfer function describes the output voltage across the current sense resistor with respect to an input voltage. The deflection amplifier model and associated simplified transfer function are shown in Figure 1.

The transfer function can be expressed as:

$$G(s) = \frac{AR_L}{LR} \frac{1}{(s+a)(s+b)}$$

where

$$a, b = \frac{AK}{R_s}$$

for critical damping. A critically damped system is preferred for calligraphic writing because it offers no overshoot with minimum settling time.

Since stroke written symbology consists of ramp currents through the deflection coil, ramp voltages must be applied at the input. From here on it is a simple matter of scaling. As-

sume that the viewing area of the CRT is 5 in. by 5 in. It takes 4.4 amps to deflect the beam from center to edge for a 5 volt input. To write a 0.1 in. stroke requires an input change of 0.2 volts. At the write rate of 0.022 in/us requires an input ramp of  $4.4 \times 10^4$  V/s. The Laplace Transform of a ramp is  $C/s^2$  where  $C = v/s$ . Then the output is:

$$H(s) = \frac{C}{s^2} G(s), \text{ then } \zeta^{-1} [H(s)] = h(t)$$

or

$$h(t) = \frac{CAR_L}{B^2 LR} \left[ t - \frac{2}{B} + te^{-Bt} + \frac{2e^{-Bt}}{B} \right]$$

$$B = \frac{AK}{R_s}$$

$h(t)$  is the voltage across the  $0.5 \Omega$  sense resistor. Since it takes

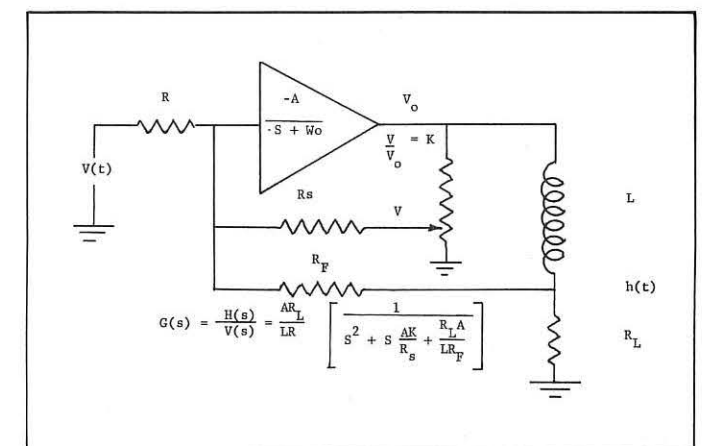

Figure 1: Deflection amplifier model and transfer function.



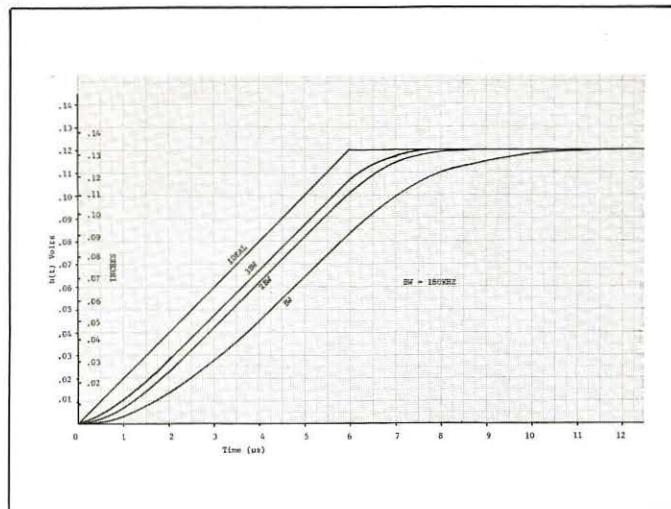

Figure 2: Current sense voltage output as a function of input ramp and bandwidth.

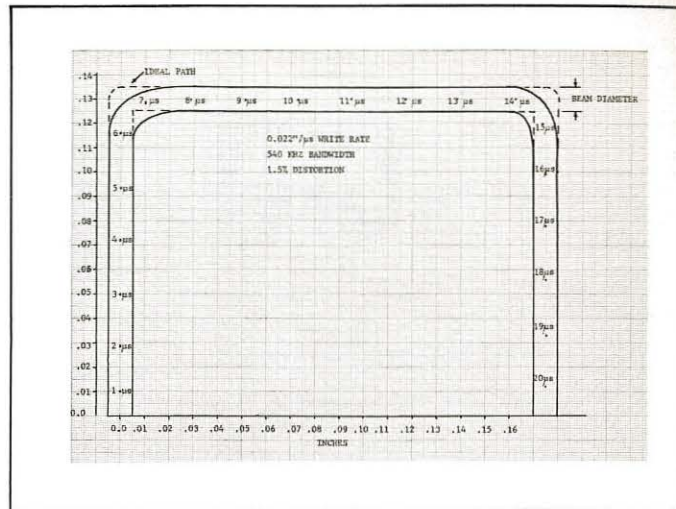

Figure 5: Beam path as a function of bandwidth and write rate. (540 kHz bandwidth.)

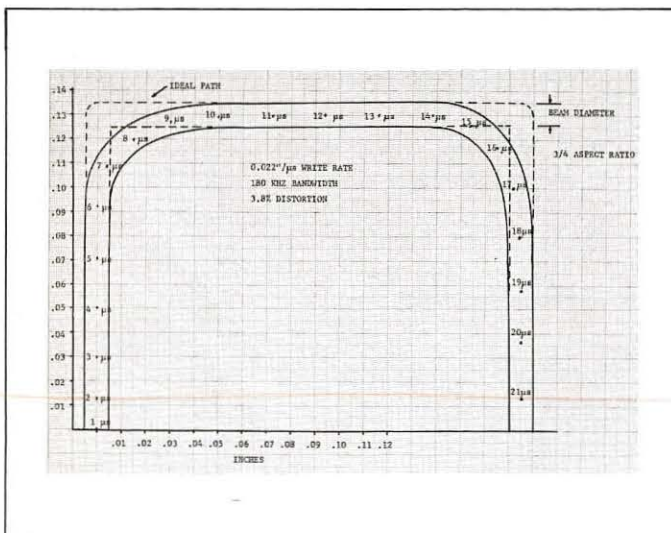

Figure 3: Beam path as a function of bandwidth and write rate. (180 kHz bandwidth.)

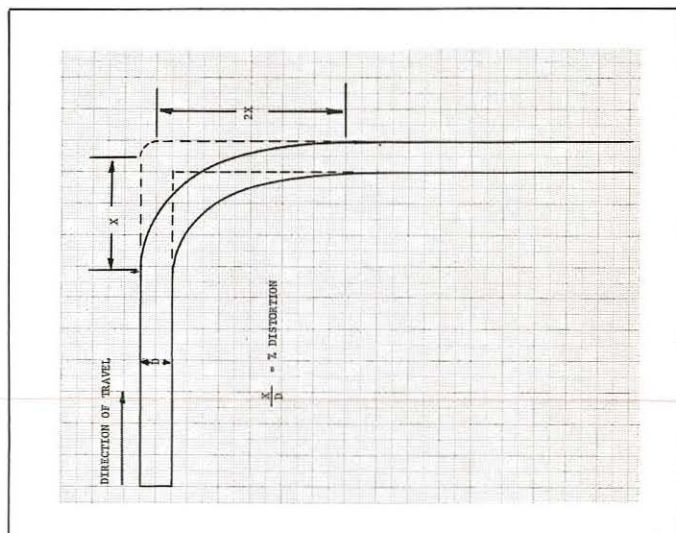

Figure 6: Percent distortion definition for a 90° turn.

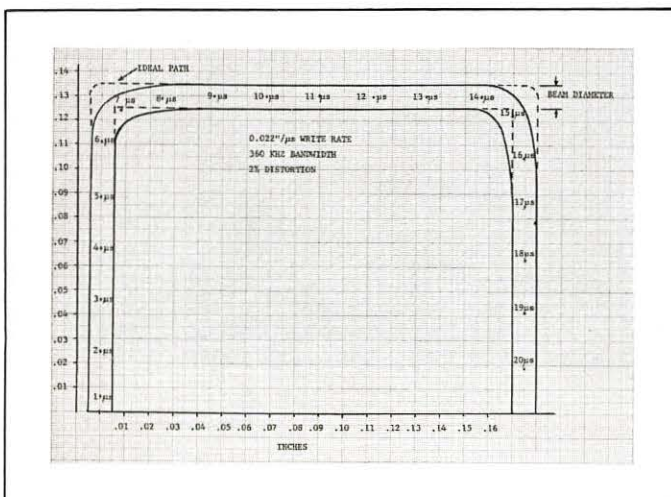

Figure 4: Beam path as a function of bandwidth and write rate. (360 kHz bandwidth.)

4.4 amps to deflect 2.5 in. the  $h(t) \times (2.5/4.4)(2) = 1.1 h(t)$  gives us inches deflected on the screen.

For the above equation, the response was calculated with the following values:

$$A = 7.5 \times 10 \text{ in.}, R_L = 0.5, L = 1.7 \times 10^{-4}$$

hence

$$B = \frac{AK}{R_s} \text{ rad/s}, B^2 R = 5 \times 10^{15}, R_s = 1 \times 10^5$$

The bandwidth B was changed in conjunction with R and K to give different bandwidth responses.

Figure 2 shows the response to a 0.022 in/us write rate input for different bandwidths. With the information from Figure 2 it is possible to construct a beam written 90° turn for different bandwidth. This is shown on Figures 3, 4 and 5.

Continued on page 30

# NEW! MAIL ORDER ONLY!

## PROFESSIONAL QUALITY

# LOW-NOISE CASSETTES



LOW NOISE  
HIGH DENSITY  
CALENDERED

Compact  
Cassette

LIFETIME GUARANTEE

**Project: Media Cassettes** will give you virtually noise-free high-fidelity reproduction. This is the same cassette used by record companies and professional duplicators. Lifetime guarantee.

**C-30 .60      C-90 .95**  
**C-60 .70      C-120 1.10**

Packed 10 cassettes to a carton. Add .50 per carton for shipping.

**Project: Media Sampler: 2 C-30, 3 C-60, 3 C-90 and 2 C-120, \$8.35, Add 50c for shipping. (5% sales tax in Calif.)**

**Order today!**

Please enclose a check or money order. Schools, religious organizations, city, state or Federal Agencies may order on open account using official purchase orders with reimbursement vouchers attached. Companies and corporations with Dunn & Bradstreet Ratings may also order on open account.

**The PM Company**  
**825 S. Barrington Ave., Los Angeles, Calif. 90049**



5). The Character Generator ROM, which generates the character video, also generates the necessary control signals to provide proper keying information to edge the character. The techniques are very different. The Vidifont approach is simpler, more accurate since video noise on adjacent lines cannot possibly affect the edging, and more reliable since the electronics required to control delay lines are not necessary. From an aesthetic point of view, the Vidifont is capable of providing a more pleasing display, since the edging characteristics can be altered at will, by changing the memory contents. All of the delay line approaches to this problem are totally dependent on signals generated on adjacent lines of the same field.

Summary and Conclusions

The basic differences between the Vidifont and other similar devices are more than the high quality of the characters. The Vidifont was designed to synthetically produce graphic arts style characters. Utilization of the latest digital techniques and the creation of synthetic characters of high resolution and quality allows the user to mix supers and synthetically generated titles without the viewing audience noting an obvious difference. The Vidifont provides a balanced set of capabilities designed to permit information display with a minimum amount of observer error (Figure 6). Through the use of plug-in units, sets of stored characters can be changed at will. The user is no longer limited to a choice of high-quality characters requiring extensive preprogram preparation and low-quality characters when responding instantaneously to changes in titling requirements as in a news or sports environment.

References

1. R. Bass, "The Development of CBS News 36," *The Journal of Typographic Research*, Vol. 1, No. 4, Oct 1967.
2. G.L. Bell, "Studies of Display Symbol Legibility, Part XVI: The Legibility of Teletypewriter Symbols on Television," prepared for Command Systems Computer and Display Div., Electronic Systems Div., Air Force Systems Command (USAF), L. G. Hanscom Field, Bedford, Mass., No. EST-TR-67-104 (MTR-388), Apr 1967.
3. G.C. Kinney and D.J. Showman, "Studies in Display Symbol Legibility, Part XVIII: The Relative Legibility of Upper Case and Lower Case Typewritten Words," prepared for Command Systems Computer and Display Div., Electronic Systems Div., Air Force Systems Command (USAF), L.G. Hanscom Field, Bedford, Mass., No. EST-TR-67-106 (MTR-394), June 1967.
4. A.S. Neal, "Legibility Requirements for Educational Television," *Information Display*, Vol. 5, No. 4, pp 39-44, July/Aug 1968.



Stanley N. Baron is Section Manager, TV-Compatible Display, Electronic Systems Dept., CBS Laboratories, Stamford, Conn. He is responsible for the design and development of synthetic television-compatible video generators and has project responsibility of the CBS Vidifont titler. Before joining CBS Labs in 1965, Mr. Baron was employed as a senior engineer by Sylvania Electronic Systems, Amherst Laboratories, and as an electronics engineer at General Electric Corp. He graduated from New York University with a BSEE and MSEE.

From these figures we can define a percentage of distortion for a 90° turn (see Figure 6). This shall be the ratio of the shortest distance from when the beam starts to turn to the actual corner over the diameter of the beam. Figure 7 shows this relationship.

From the information obtained it can be shown that a linear relationship exists between write rate and bandwidth. That is, for a certain percentage of distortion to stay constant, write rate and bandwidth have to be changed by the same percent. For instance, doubling the write rate requires doubling of the bandwidth to maintain the same percent of distortion. Figure 7 shows this relationship.

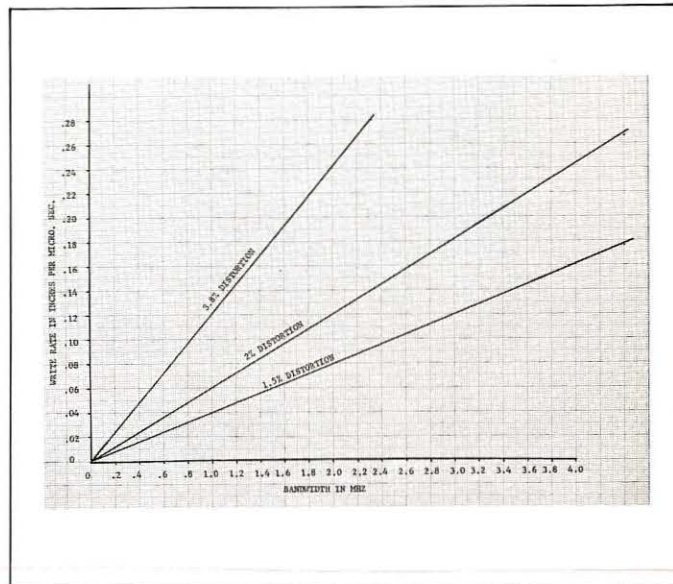

Figure 7: Write rate as a function of bandwidth and distortion.

Conclusion

This report does not cover all of the different possible write configurations. It was decided that a 90° turn is generally the worst case and also the beam has settled down to its true location before another turn is negotiated. Plotting graphs for all the different beam paths that one could imagine would be endless. For such rare cases individual analysis must be done.



Alfred Pletz Jr. received his BS degree in electronic engineering from the University of California, Berkeley, and his MS from Seattle University. He is presently with the Advanced Development Group at Kaiser Aerospace and Electronics, Palo Alto, Calif., where he is developing low power aircraft CRT display systems. Prior to joining Kaiser, Mr. Pletz was with Boeing's Instrumentation Group and was awarded a patent for developing and designing an automated electronic rigging system for aligning the wing control surfaces of Boeing's 707, 727 and 747.

# The gift for the man who knows everything.

The computer professional. He knows how perishable knowledge is, and the need to keep abreast of rapidly changing technology.

The computer user. He knows the value of seeing what's new, and finding answers to his specific problems.

The marketing manager. He knows the Fall Joint is this year's major national conference, and the prime environment for meeting his customers and prospects. The EDP press. Largest gathering in the field. They know how to get a peek at next year's news before it happens.

The '72 FJCC has a lot going for the people who know everything, and want to keep it that way. If you're one of them, chances are you know where you're going in this business. Then you also know that your business will be going to Anaheim in December.

To the '72 FJCC. Big, bold and different. Sixty-one information packed sessions and seminars, half of which are user oriented.

This year's largest display of computer hardware, software and services. And all right in the heart of the growing West Coast EDP market.

The men who know everything will be at the '72

FJCC. Give yourself a gift and be there too. Treat yourself and your associates to the most precious gift of all. The gift of knowledge. Send the Gift Certificate for complete registration, hotel and conference information.

**The Gift Certificate**

American Federation of Information Processing Societies, Inc.  
210 Summit Avenue  
Montvale, New Jersey 07645

Gentlemen:

- Yes, I'm interested in attending the '72 FJCC. Please send full information.
- My company is interested in exhibiting at the '72 FJCC. Please send details.

NAME \_\_\_\_\_  
 POSITION \_\_\_\_\_  
 COMPANY \_\_\_\_\_  
 ADDRESS \_\_\_\_\_  
 CITY \_\_\_\_\_ STATE \_\_\_\_\_ ZIP \_\_\_\_\_

**The '72 FJCC. Big, bold and different.**  
ANAHEIM - DECEMBER 5-7



## Are Ghost Images Confusing Your Customers' View?

Blurring the signals on oscilloscopes? Dimming the images on TV monitors or radar displays? Obscuring the data on computer terminal displays? Do your customers have to look twice at any of your cathode ray tube display devices to get the proper information?

## Let OCLI Help You Clear Things Up!

HEA—a high efficiency multilayer antireflection coating—reduces reflections over the visible range of the spectrum by a factor of 10 over uncoated glass. Deposited directly on the curved surface of a CRT or its faceplate, HEA will transform

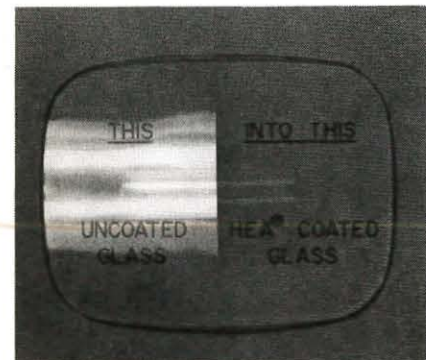

(unretouched photograph)

The coating can be deposited on either acrylic or glass, is extremely durable and can be cleaned and handled with a minimum of care.

HEA for Display Devices is only one of OCLI's large family of HEA coatings designed to improve the view through nearly every type of visual optical system. Find out more about how OCLI can brighten images. Write to our Marketing Department, Technical Products Division.

## OCLI OPTICAL COATING LABORATORY, INC.

Technical Products Division

P.O. Box 1599, Santa Rosa, California 95403.  
Teletype 510-744-2083. Telephone 707-545-6440.

Manufacturing facilities serving Europe  
OCLI Optical Coatings, Ltd.  
Dunfermline, Fife, Scotland

Represented in Japan by Hakuto Co., Ltd., Tokyo;  
France, Belgium, Netherlands and Luxembourg  
by Techomation of Paris, Brussels & Amsterdam;  
and in Germany, Austria, Switzerland and Italy by  
Betzelt GMBH, Munich.

## New Literature

### Analog Circuits

Analog Devices Inc., Norwood, Mass., has published an 184-page product guide for the designer of instrumentation and systems which accept, analyze, process, convert and react to analog signals. All current products are catalogued and classified, and selection criteria and interpretative commentary are also offered. Amplifier products, converter products, digital panel meters, function modules and accessories and linear integrated circuits are detailed.

Circle Reader Service Card No. 10

### COM Applications

The advantages of replacing conventional computer print-out with microfilm is the subject of an application profile brochure available from UCC Communications Inc., proprietary products subsidiary of University Computing Co., Dallas, Tex. Written around the use of COM by Blue Cross of Southern California, the brochure traces the step-by-step evolution, from trial to complete conversion, from paper files to microfiche projection at customer inquiry service stations.

Circle Reader Service Card No. 11

### Displays & Controls

A 20-page brochure describing displays and controls designed and built by the Singer Co.'s Kearfott Div., Little Falls, N.J., is available as catalog C71-0571. Electroluminescent and LED displays are described for a variety of Apollo and Skylab spacecraft applications, as well as for an orbital rate drive electronic hybrid computer using electroluminescent panel lighting. Display devices include digital indicators, event timers, mission clocks, helium temperature and pressure indicators, propellant quantity displays and metabolic readout units. Controls and display/control combinations are detailed for numerous aircraft applications. All displays and controls described are complemented by illustrations.

Circle Reader Service Card No. 12

### Electromagnetic Shielding

From Eagle Magnetic Company Inc., Indianapolis, Ind., comes an eight-page catalog outlining repeatable and non-destructive electromagnetic shielding test procedures. Among the areas covered are shielding calculations, shield design considerations, a sheet and foil guide and photomultiplier availabilities.

Circle Reader Service Card No. 13

### Color Display Brochure

Spatial Data Systems, Goleta, Calif., has published an eight-page technical brochure indicating various use-applications for its model "805 Color Display." The publication describes central-feature highlights of the Display which include Color Display, Grey-Scale Display, Graphics and Alphanumeric, Color Keyboard and Cursor and Joystick. The brochure includes a full-page photograph of the Display and a

page block diagram which illustrates make-up and design components. An introductory section discusses applications and data sources relating to the Display process.

Circle Reader Service Card No. 14

### Magnetic Shielding

A 12-page brochure on magnetic shielding has been issued by Allegheny Ludlum Steel Corp., Pittsburgh, Pa. The booklet covers shielding design, testing and fabrication. Included are discussions on selection of shielding materials, evaluation of shielding effectiveness and a graphic examination of relative permeability and attenuation vs. field strength and thickness.

Circle Reader Service Card No. 15

### Indicator Lights

Ultra-miniature indicator lights are the subject of a 20-page brochure published by Dialight Corp., Brooklyn, N.Y. The brochure details their complete line of lights including incandescent, neon and light-emitting diode types used in computer and peripheral equipment markets as well as other areas where miniaturization is required. The catalog includes data on characteristics and performance for each device, their applications, electrical and mechanical information and diagrams. Among the light described are plug-in Datalamp cartridges, Datalamp holders, indicator lights for use with cartridges, military indicators, permanent lamp indicator lights with nonreplaceable neon light sources, and speed clip with cartridge connectors.

Circle Reader Service Card No. 16

### Computers For Bibliographic Search

Donald E. Walker, PhD, from Stanford Research Institute has edited *Interactive Bibliographic Search: The User/Computer Interface*, a 375-page volume which examines current developments and trends in the use of computers for bibliographic search. The four-part work includes discussions by various experts on general design philosophy, command query and display structure, user needs, feedback and training, evaluation and design criteria, and the development of a function/feature list for interactive bibliographic searching. The book is published by the American Federation of Information Processing Societies (AFIPS).

Circle Reader Service Card No. 17

### Optical Storage and Displays

The first-quarter issue of the *RCA Review*, published by RCA/David Sarnoff Research Center, Princeton, N.J., summarizes new research into the development of improved lasers and better control and storage devices. The issue includes technical papers on 13 different aspects of this technology. Among these are two which deal with lithium niobate as a medium for holographic recording and storage, two others which describe the RCA HoloTape system and one which examines liquid crystals and their display applications. Other papers cover the theoretical considerations in information storage and offer a representative number of media for holographic and direct-image storage.

Circle Reader Service Card No. 18

## Correspondence

### Nice Going

Sirs: The article, "A Logic Character Generator For Use in a CRT Text Display" by A.A.V. Thomas and W.E. Mennie, which appeared in the Mar/Apr issue, was very well written.

M.J. Eager  
Ohio University Computer Center  
Athens, Ohio

Sirs: I particularly enjoyed reading your article on "A Logic Character Generator."

L. Sutton  
Zenith Radio  
Niles, Ill.

### ... And Not So Nice

Sirs: I disliked the first two articles of your Mar/Apr issue ("A Logic Character Generator" and "Interactive Graphics"). The content and substantiation were far too thin.

B.B. Jancowskis  
NAFI  
Indianapolis, Ind.

Sirs: In the Mar/Apr issue most of the technical information is several years old. Also, the editorial writer seemed very confused, and used double-talk to conceal a patent lack of depth.

L. Stewart  
Kester Associates  
Van Nuys, Calif.

### Humanistic Approach

Sirs: I would appreciate articles which more thoroughly discuss the human response to displays, not simply a description of displays and their physical make-up.

B.J. Giddings  
Elliott Flight Automation  
Rochester, England

### New Products

Sirs: The New Products section is a highly informative aid to anyone in information display.

M. C. Volker  
Design Engineer  
V. A. Designs  
Toronto, Ontario, Canada

Sirs: The information about New Products is very useful.

C. C. Calvin  
Manager, Real Time Computing  
Computer Technology  
Dallas, Tex.

### How About ...

Sirs: From the viewpoint of the MOS vendor, a large revolution is going on in displays. I am referring to seven-segment displays, and the revolution is in the technology ... LEDs, liquid crystals and gas tubes such as the Panoplex or Sperry. The winner or winners are in for a large reward, particularly in such consumer products as calculators and clocks. I am sure this would be an area of extreme interest to your readers. Not only is the technology and its rapid evolution confusing to many, but the application of

these displays to existing circuits and future circuit types is also an area that needs considerable exposure.

Gordon Hoffman  
Mostek Corp.  
Carrollton, Tex.

[Bear with us. An article on this very subject is already underway. — Ed.]

### Erratum

Sirs: Upon reading the article "A Logic Character Generator For Use in a CRT Text Display" in Mar/Apr 1972, I noticed the following two errors which could cause confusion in reading the article.

1. The list of bit values on page 13 should have read:

Bit 8 = MR1  
Bit 16 = MR2  
Bit 32 = MR3

Note: The complement of the MR bits is used. This is readily seen in Figure 13.

2. Figure 15 has a drawing error which I regret also slipped through in the original thesis. The output of the CR-MARGIN gate in the upper left of the figure should only go to gates 1,2, ... 6,7 but not to gates 8,9 and 10. The input line to gates 8,9 and 10 should be labeled TAB. Thus gates 5,6 and 7 set the X register on a carriage return which uses the margin register while gates 8,9 and 10 are used during a tabulate.

I apologize for any inconvenience which these errors may have caused your readers.

William E. Mennie  
Control Data  
Mississauga, Ontario, Canada

## CATHODE RAY TUBES

WE OFFER YOU TECHNICAL ABILITY FOR ANY SPECIAL CRT AND DISPLAY SYSTEM

CRT  
FIBER OPTIC FACE  
BACK PORTED  
MONOSCOPES  
HIGH RESOLUTION  
CUSTOM GEOMETRIES  
PHOSPHOR SCREENS  
ELECTRON OPTICS.



SYSTEMS  
FLYING SPOT SCANNERS,  
MONITORS, FIBER OPTIC  
PRINTERS, DATA TERMINALS.

DESIGN — DEVELOPMENT —  
PRODUCTION — TUBES AND  
SYSTEMS.

M. SADOWSKY

S. CARLISLE

P. KEEGAN

## SPECIAL PURPOSE TUBE COMPANY

14746-C RAYMER ST., VAN NUYS, CA. 91405  
Tel. (213) 989-4610

**FREE YOKE SELECTION KIT**  
Information you need to know about selecting and specifying a precision yoke for your CRT display. Indicates the interaction between circuitry, CRT and yoke. Includes an application checklist to simplify your work. Send for your kit.

SYNTRONIC INSTRUMENTS, INC.  
100 Industrial Road Addison, Ill. 60101 (312) 543-6444

**syntronics**



## ID Products

### Polarized Axis Finder

The Polacoat Polarized axis finder is a scientific instrument for detecting and measuring the direction and amount of polarization. Polacoat



Inc., Cincinnati, Ohio, claims the unit is a durable, laminated glass assembly which uses one of the basic operational laws of light in a way that is simple and foolproof. It can be used for scientific readouts and for detecting birefringence and its sign.

Circle Reader Service Card No. 21

### Magnetic Shield

A single layer high permeability AD-MU80 shield is now available from Ad-Vance Magnetics Inc., Rochester, Ind. The Shield optimizes scan converter tube performance by diverting external magnetic fields which might prevent proper tube functioning, Ad-Vance claims. Construction features include four rolled-in beads for increasing structural rigidity and enhancing concentricity, and hydroform construction of the associated sections. All necessary joining parts and seams are heliarc welded.

Circle Reader Service Card No. 22

### Intensifier Vidicon

Ebitron 9777, an intensifier vidicon, employs electron bombardment induced conductivity to produce television pictures at illumination levels down to half-moonlight conditions. Emi-tronics Inc., Plainview, N.Y., says the very wide level range over which the tube operates enables it to be used under almost any lighting conditions. A suitable combination of image and scanning sections gives a small sized tube which, with coils, is no bigger than a conventional 26 mm vidicon, but gives a sensitivity approximately 300 times greater.

Circle Reader Service Card No. 23

### Automatic Copy System

Available from W-F Products Inc., Denver, Colo., is a camera accessory for use in the production of microfilm. The system consists of a camera table-mounted perforated Platen connected by flexible tubing to a vacuum control cabinet. Vacuum is terminated immediately after the shutter closes, allowing film pull-down time to be used for changing copy. According to W-F, the system paces the operator and results in improved production rates and higher quality film.

Circle Reader Service Card No. 24

### LED Display Panels

Display Devices Inc., Encinitas, Calif., has made available custom fabricated light emitting diode display panels up to 30 in. x 40 in. in size. Display Devices claims that a multilaminar construction technique makes the production possible, and allows a clearly visible point source in high ambient light environments. Provisions for switch holes and other panel accessories can be provided, and visible graphics may be surface or subsurface printed.

Circle Reader Service Card No. 25

### Visible Character Generator

Integrated Memories Inc., Wilmington, Mass., has introduced the "See-C-Rom," a character generator where the characters are literally visible to the naked eye on the memory array and are the same shape as will appear on the output device. According to Integrated Memories, any type character or figure can be added, revised or eliminated by a non-technical person without having to understand the associated electronics such as address and decoding networks. The Rom has up to 128 standard characters — plus the optional capacity for up to 128 additional characters.

Circle Reader Service Card No. 26

### Digit Counter Display

Solitron Devices Inc., San Diego, Calif., announces the CM4100 3½ Digit Counter Display Device, part of its LSI Complementary MOS line. According to Solitron, the unit is a low power complementary MOS/LSI universal 3½ decade counter with BCD data storage and seven segment decoders and drivers. It is ideal for DVM, DPM and digital counter applications. The device features a typical low operating power of 2 mW; a battery compatibility of  $V_{DD} = +5.0 V \pm 20\%$ ; protected inputs; single supply voltage; 24 or 28 pin DIL packaging; high noise immunity; compatibility with TTL, DTL and CMOS logic; and insignificant zero blanking.

Circle Reader Service Card No. 27

### Graphic Display Systems

Two systems for interaction between graphic displays and digital information have been developed by Science Accessories Corp., South-

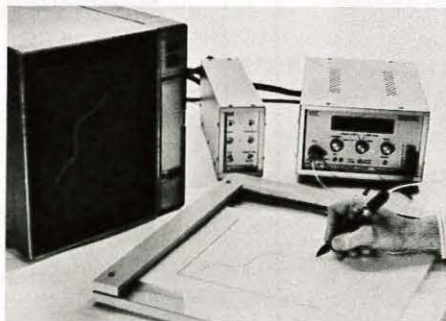

port, Conn. System 2005, according to Science Accessories, has a memory scope which presents the operator with an immediate graphic response — reconstructing the curve from the digital information to verify its accuracy or, in conjunction with a computer, creating a new display resulting from the graf/pen-traced infor-

mation being processed in accordance with a stored problem. In System 2006, the graf/pen sensors are mounted directly on the face of the scope so that the graf/pen can be used to directly provide digital coordinates corresponding to any location on the screen. Science Accessories says the graf/pen can operate in either a "single-shot" mode to provide discrete point location information or in a "continuous" mode to trace lines and curves.

Circle Reader Service Card No. 28

### High Temperature Lampholder

A high temperature lampholder, Series 4385, has been introduced by Drake Manufacturing Co., Harwood Heights, Ill. Series 4385 lampholders are double contact, bayonet type with leads. Some applications are in projectors and copying machines, high intensity spotlights, floodlights and lighted signs (indoor and outdoor); and illuminated displays for trade shows, expositions and advertising. According to Drake, they may be used in all types of commercial and industrial equipment and systems utilizing high temperature, high wattage lamps.

Circle Reader Service Card No. 29

### Display Unit

Owens-Illinois Inc., Toledo, Ohio, introduces the Model 80-33 display unit. The company claims the panel is capable of displaying illumi-



nated letters, numbers, graphs or hand-written signatures. The unit measures 2½ x 8 in. in surface dimension, has a matrix of 80 x 256 lines and has a resolution of 33 lines per in. The display unit can be selectively written or erased at any point, as well as bulk erased. Approximately 1,400 5 x 7 dot characters can be written each sec in serial address.

Circle Reader Service Card No. 30

### Digital Graphics Generator

A digital graphics generator system capable of producing multicolored images up to 40 x 60 in. on paper, transparencies and virtually any similar material is being marketed by Data Corp., a subsidiary of the Mead Corp., Dayton, Ohio. From a variety of input media (analog or digital), the Data Digital Graphics Generator converts digitized images into black and white or multicolored images — pictorial, alphanumeric, maps, geometrics and other graphic display techniques, according to the company. The unit places digitally-controlled microscopic ink droplets of uniform size on the recording medium. Placement is controlled by electrostatic charge.

Circle Reader Service Card No. 31

## We take pride in our Vidicons of quality

THOMSON-CSF standard and special purpose Vidicons are built to meet the highest performance standards - the results will show in your improved equipment performance:

low lag and high sensitivity ■ ■ higher resolution  
excellent raster linearity ■ ■ optimum signal uniformity

Our broad experience in diverse fields has also led THOMSON-CSF to develop special Vidicons for: U. V., I. R., X-Ray, slow scan, nuclear, military, space and the most sophisticated Television applications.

## DON'T COMPROMISE

For more informations on these tubes, circle the Reader Service Card or contact us directly.



**THOMSON-CSF**

THOMSON-CSF ELECTRON TUBES, INC. / 50 ROCKEFELLER PLAZA / NEW YORK, N.Y. 10020 / (212) 489-0400

France - THOMSON-CSF Groupement Tubes Electroniques / 8, rue Chasseloup-Laubat / 75 PARIS 15<sup>e</sup> / Tél. 566.70.04  
Germany - THOMSON-CSF Elektronenröhren GmbH / Am Leonhardsbrunn 10 / 6 FRANKFURT/Main / Tel. 70 20 99  
Italy - THOMSON-CSF Tubi Elettronici SRL / Viale degli Ammiragli 69 / ROMA / Tel. 63.80.143  
Sweden - THOMSON-CSF Elektronrör AB / Box 27080 / S 10 251 STOCKHOLM 27 / Tel. 08/600990  
United Kingdom - THOMSON-CSF Electronic Tubes Ltd / Bilton House, Uxbridge Road, Ealing / LONDON W5 2TT/Tel. 01-579 1857



## ID Readout

### Electro-Optics Conference

The Palais Des Expositions in Geneva will be the sight of the 1st European Electro-Optics Markets and Technology Conference and Exhibition. Organized by Mack-Brooks Exhibitions Ltd., the conference will convene September 13-15 and is expected to attract executives and specialists from every sector of the industry and from over 26 different countries.

Coordinating the conference program is Herb Elion, a world authority on electro-optics and a top adviser with consultants Arthur D. Little of Cambridge, Mass. Elion has planned 12 specialized sessions for the three-day program, with in-depth technical papers to be presented during the day and general-appeal marketing and applications stories to be the early evening fare. In particular, four discussion sessions are planned on optical communications, markets for electro-optical systems, video-players, and electro-optics in medicine.

For information, contact Kevin Smith, 7 Ruvigny Mansions, London S.W. 15, England. Telephone: (01-) 242-9286 or (01-) 788-8432.

### Conference on Display Devices

The 1972 IEEE Conference on Display Devices will be held on October 11-12, 1972, in the United Engineering Center Auditorium, New York City. Sponsored by the Electron Devices Group of The Institute of Electrical and Electronics Engineers (IEEE) and the Advisory Group on Electron Devices, the program will cover all of the disciplines relevant to the re-

search, development and design of electronic display devices.

Among the areas of particular interest are cathode-ray tubes, solid-state light emitters, plasmas, liquid crystals, lasers, holography, light valves and projection displays. Related topics such as drive address and control techniques, phosphors, fiber optics, electron optics, photochromics and cathodochromics, recording media directly applicable to displays, new phenomena, pertinent operational characteristics and measurement techniques are to be included.

The deadline for abstracts has past, but late news papers will be considered if 75 word abstracts for ten minute papers are received before September 11, 1972. For information, contact Louis N. Heynick, Physical Electronics Group, Stanford Research Institute, Menlo Park, Calif. 94025.

### Fall Joint Computer Conference

The 1972 Fall Joint Computer Conference, originally slated for November 14-16 in Las Vegas, will be held December 5-7 in Anaheim, Calif. Sponsored by the American Federation of Information Societies (AFIPS), the conference will convene in the Anaheim Convention Center.

According to Dr. Robert Spinrad, conference general chairman, the fall theme will be The Coming of Age, which emphasizes the responsibility of the computer field to stay abreast of social issues and user needs in this, the 21st year of its commercial activity. Accordingly, the significant areas to be covered include facilities management, and user applications and requirements.

For further information contact T.C. White, AFIPS Headquarters, 210 Summit Ave., Montvale, N.J. 07645, or call (201) 391-9810.

## Make your own filmstrips!



### Do-It-Yourself Filmstrip Kit Saves You Money

A complete kit, "How to Make Professional Quality Filmstrips on a Pinch-Penny Budget," is designed for educators, businessmen, sales executives and amateurs to produce their own filmstrips at an extremely low cost. This kit shows how to write, photograph and coordinate your script in exactly the same efficient procedure used by professional film makers.

All professional tools are included: complete step-by-step instruction book, storyboard pads, script forms, sequence sheets, acetate cropping guide for 35mm and 2 1/2 x 2 1/2 film, and professional field chart. **Project: Filmstrip** will also provide professional consultation and complete production facilities if needed.

**Complete kit, \$10.00 postpaid (add 5% California sales tax).**

PROJECT: FILMSTRIP

825 S. Barrington Ave., Los Angeles, California 90049

## Advertisers

Arvin Magnetics .....	12
Auto-Trol Corporation .....	39
Burroughs Corporation .....	Back Cover
Computing Devices of Canada .....	26
Conrac Corporation .....	8
Dicomed Corporation .....	2
Keuffel & Esser .....	11
Optical Coating Laboratory Inc. ....	32
Polacoat Incorporated .....	10
RCA Electronic Components .....	5
SC Electronics Incorporated .....	7
Special Purpose Tube Company .....	33
Syntronic Instruments Incorporated ..	33
Thomson CSF .....	35
Westinghouse Electric Corporation/ Tube Division .....	17

# auto-draft™ draws anything

auto-trol  
corporation

Inter-Active graphics is the technical name. What it means is that Auto-Draft, a completely self-contained hardware/software system, can turn out finished drawings in a fraction of the time with greater

accuracy than a whole room full of draftsmen. On top of that

there's no time lost for runny noses, coffee breaks, or paid vacations.

Basically, it produces finished drawings from rough sketches, photographs and other input mediums. The result is faster turn around time, lower costs, drawing standardization, and easy expansion as the work load increases. Auto-Draft can be used for general drafting, architectural drawings, mapping, generation of IC and PC artwork, mechanical drawing or just about any type of drafting application.

The system is modular so you can start small and expand at an economical pace. People such as General Motors, Union Oil, Alcan, Bell Labs, Motorola, U.S. Navy, California Highway Department, U.S. Geological Survey and hundreds of others have used Auto-Trol equipment to satisfy their computer graphics needs. Call for an Auto-Trol Representative to survey your drafting requirements.

**AUTO-TROL CORPORATION** • 6621 West 56th Avenue • Arvada, Colorado 80002 • (303) 421-5670  
Denver, New Jersey, Atlanta, Los Angeles, San Francisco, Paris (EAC International)